

# ***Multi-Disc Dehydrators***

**MDQ / MDC / JD**



# Multi-Disc Screw Press Dehydrators



◀◀ MDQ

MDC ▶▶



Multi-disc screw press dehydrators utilize both gravity filtration and screw displacement compression systems. The pitches of the screw blades are gradually narrower toward the cake outlet in order to reduce the volume of cake, so the coagulated sludge that has been concentrated by gravity filtration is dehydrated by compression.

The dehydrator main unit requires lower motor output and the filtration surface consists of a multiplicity of self-cleaning capable discs, and seldom clogs. Thus, the dehydrator can be used continuously. The main unit of the dehydrator is of multi-shaft design. Therefore, when two or more main units are configured into one machine, any individual shaft can be repaired or serviced without interrupting dehydration operations.

Multi-disc screw press dehydrators can cope with a wide range of sludge concentrations, and also stably dehydrate sludge that contains high oil content.

---

**T**surumi's dehydrators offer a compact, easily installed turn-key package. These dehydrators produce less noise, require less energy and less flush water than competitive equipment, thus providing an economical and eco-friendly solution to dehydration applications.

---

## *Multi-Disc Dehydrators*

### JD



Multi-disc dehydrators utilize both gravity filtration and compression dehydration systems. The “filtering rollers” consist of alternating thin metal discs and resin discs, and are arranged in two (upper and lower) tiers. The coagulated sludge is fed between the rollers and dehydrated by compression while being conveyed toward the sludge outlet by the rotating action of the rollers. The dehydrator main unit requires lower motor output and the filtration surface consists of a multiplicity of self-cleaning capable discs, and never clogs. Thus, the dehydrator can be used continuously. Multi-disc dehydrators can cope with a wide range of sludge concentrations, and also stably dehydrate sludge that contains high oil content or organic sludge that contains high quantities of inorganic substances.

# Tsurumi's technology works effectively in a variety of industries and applications.

## Applications

- Excess sludge from biological processes
- DAF froth
- Various types of mixed sludge
- Coagulated sludge



Excess Sludge at Industrial Plant (MDQ-202)



Mixed Sludge at Dairy Product Plant (MDQ-203)



Excess Sludge at Wastewater Treatment Plant (MDQ-205 x 2)



Mixed Sludge at Industrial Waste Treatment Facility (JD-500)



Mixed Sludge at Confectionery Plant (JD-500)



Excess Sludge at Noodle Production Plant (JD-1000)

# Criteria for Selecting a Model

## Sludge Concentration

Less than 2%

Multi-Disc Screw Press Dehydrators MDQ / MDC

2% or higher

Multi-Disc Dehydrators JD

## Inorganic Content

Less than 40%

Multi-Disc Screw Press Dehydrators MDQ / MDC

Less than 60%

Multi-Disc Dehydrators JD

# Comparison in Terms of Energy Consumption/Amount of Flush Water

## Comparison in Terms of Energy Consumption

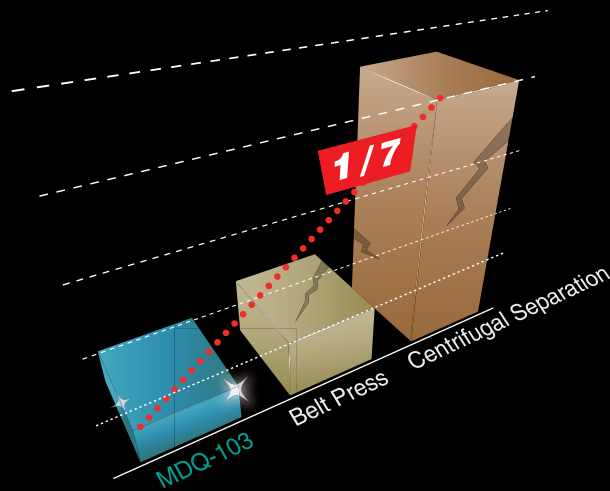

### MDQ-103

Treating Capacity 40lbsDS/h  
Total Motor Output 1.3HP

### Belt Press

Treating Capacity 33lbsDS/h  
Total Motor Output 1.9HP

### Centrifugal Separation

Treating Capacity 44lbsDS/h  
Total Motor Output 9.9HP

## Comparison in Terms of Amount of Flush Water (8-hour operation)

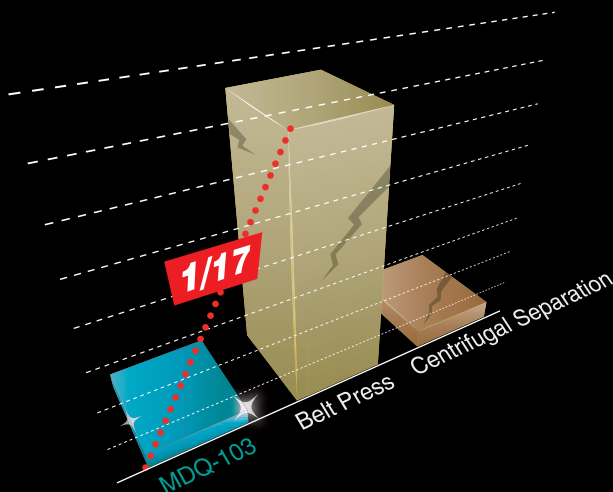

### MDQ-103

Treating Capacity 40lbsDS/h  
Flush Water 0.21GPH

### Belt Press

Treating Capacity 33lbsDS/h  
Flush Water 3.7GPH

### Centrifugal Separation

Treating Capacity 33lbsDS/h  
Flush Water 0.26GPH

MDQ  
MDC

**Multi-Disc  
Screw Press Dehydrators**

Wide product lineup with treating capacity  
in a range of 6 to 475 lbsDS/h



MDQ

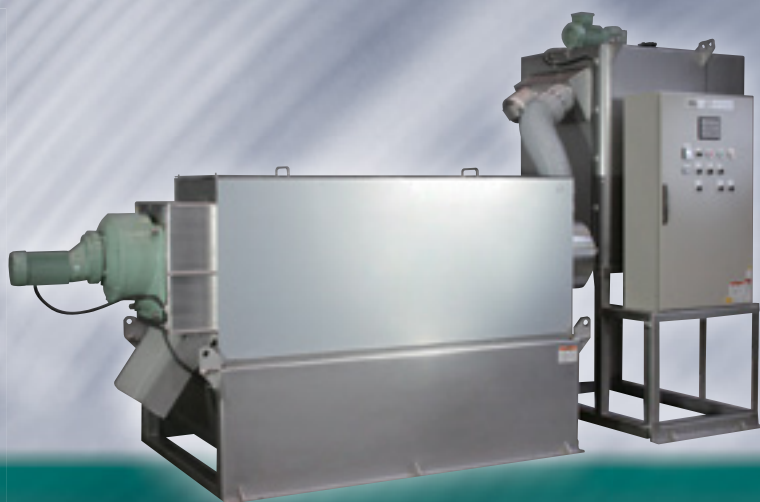

MDC

# Features

01

## Wide Product Lineup

Tsurumi's multi-disc screw press dehydrators are available in wide lineup, with treating capacity in a range of 6 to 475 lbsDS/h, and with five shafts at maximum. Users can select the best equipment from 13 models according to the size of targeted treatment plant.

02

## Energy-saving & Compact Design

The MDQ/MDC series features energy-saving construction designed to dehydrate sludge by "gravity filtration + screw volume reduction." The equipment is of compact unitized construction with all of the necessary accessories and control panel mounted on a common base\*, and therefore can be readily installed in very limited floor space.

\* Not applicable to the MDC-series.

03

## Automatic Operation

Operators can begin automatic operations of the dehydrator and related accessories by simply and easily operating the included control panel.

04

## Self-cleaning Mechanism

The filtration surface consists of a multiplicity of discs and a self-cleaning mechanism, therefore it seldom clogs and the equipment can run continuously.

05

## Capable of Treating Oily Sludge

The equipment can stably dehydrate even sludge that contains high oil content. The dehydrator is an optimum solution for treating oily sludge such as DAF froth at food processing plants, which filter cloth systems and centrifugal separation processes cannot readily handle. Thus, the equipment boasts a higher solid capture rate.

06

## Capable of Treating Low Concentration Sludge

The dehydrator has both a gravity concentration section and compression dehydration section, and therefore can cope with a wide sludge concentration range of 0.5 to 2.0%.

07

## Small Amount of Flush Water and Low Maintenance

Because the equipment is constructed to avoid clogging, flushing is not needed in order to restore the original filtration performance. Only showering with a minor amount of water is necessary to wash away sludge that oozes from the dehydration section. Thus, the amount of flush water needed is minimal, and routine maintenance work is not needed.

08

## Inhibition of Secondary Pollution

The dehydrator main unit features a semi-enclosed construction, and runs at an extremely low speed, therefore sludge does not splatter from the equipment. The dehydrator is of eco-friendly design that generates low noise and vibrations, and emits virtually no odors.

09

## Multi-shaft Construction

When two or more dehydrator main units are configured into one machine, any individual shaft can be repaired or serviced without interrupting dehydration operations.



# Structure

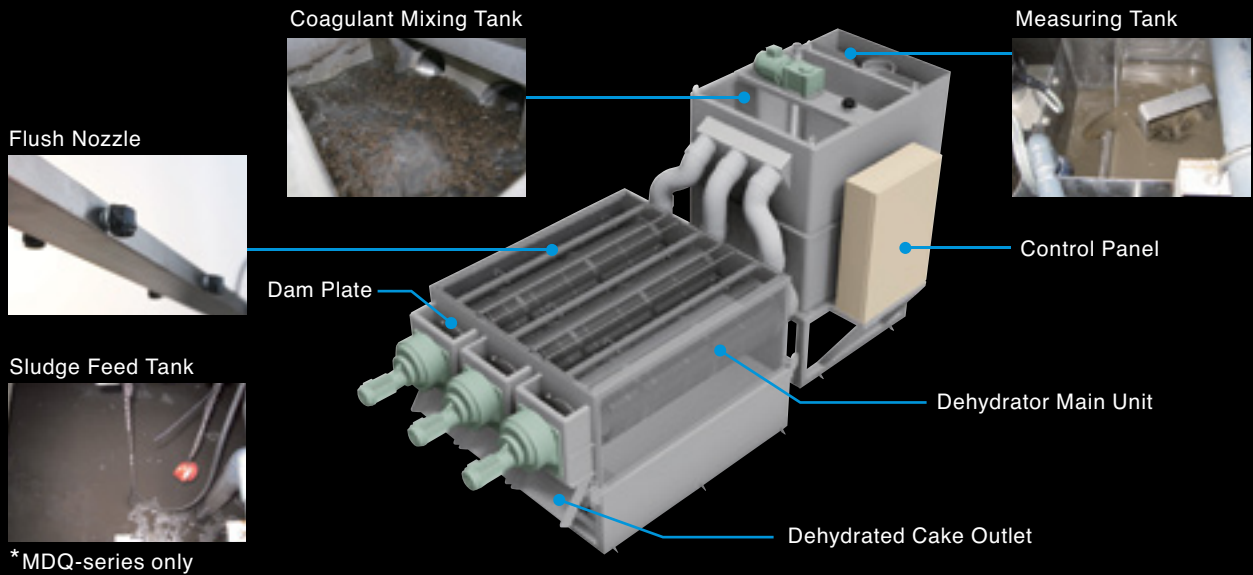

# Mechanical Principle

The main unit of the multi-disc screw press dehydrator contains a multi-disc mechanism where ring-shaped “fixed discs” and “movable discs” are alternately arranged at a regular clearance around a “screw shaft.” The main unit consists of a “support frame” that supports the multi-disc structure and a “dam plate” at the end of the screw shaft.

Internal Construction of Dehydrator Main Unit

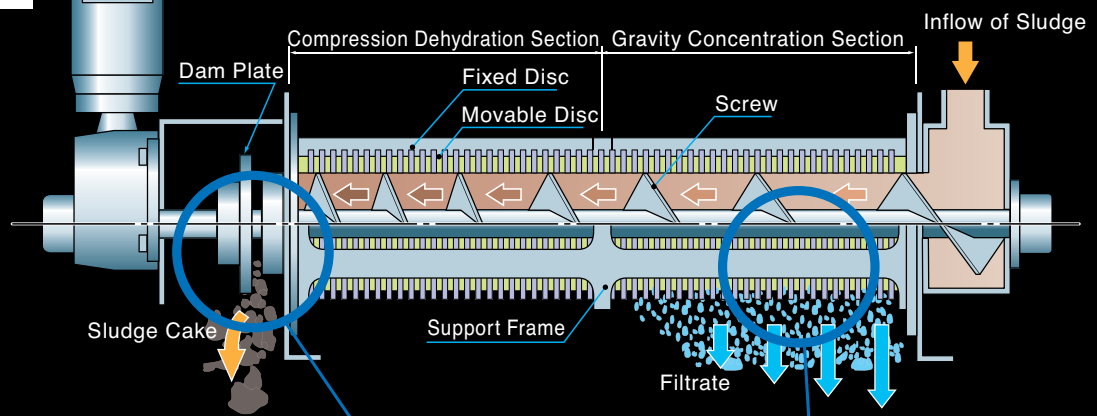

## Movable Disc Bore Surface Sliding Contact System

The bore of the movable disc remains in contact with the outer circumference of the revolving screw blades while sliding, therefore the passage area is constantly cleaned, allowing the dehydrator to stably treat sludge without clogging.

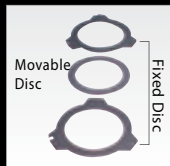

## Dehydration Process

The sludge transported by the screw is gradually compressed as the screw pitch narrows in the direction of travel, and is further compressed by the dam plate at the end of the shaft and delivered out of the dehydrator.



## Concentration Process

Most water content in the flocculated sludge flowing into the dehydrator main unit flows through the clearances (gaps between the fixed discs and movable discs) in the multi-disc structure and is then delivered outside the dehydrator by gravity filtration.

# MDQ Flow Sheet

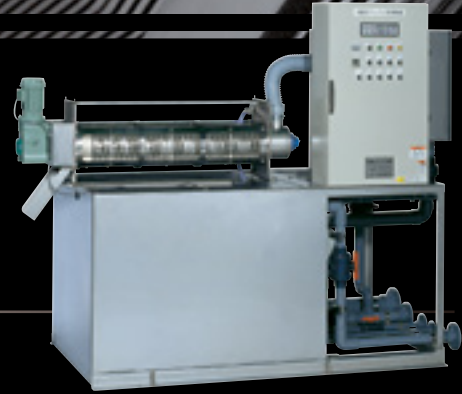

The sludge is conveyed to the sludge feed tank in the MDQ dehydrator by a sludge conveying pump (not included) in the sludge tank. The sludge in the sludge feed tank is homogenized to a uniform consistency by a mixing pump, and then fed into the measuring tank by the sludge feed pump. A predetermined amount of sludge is measured in the measuring tank and naturally flows into the coagulant mixing tank; the excess feed is naturally returned to the sludge feed tank. In the coagulant mixing tank, liquid polymeric coagulant is added to the sludge; flocking then occurs owing to the mixing action. After flock generation, the sludge overflows the coagulant mixing tank and naturally flows into the dehydrator main unit, where the filtrate is separated and the resultant dehydrated cake is delivered out of the dehydrator.

The coagulant to be used can be selected from several combinations of an inorganic coagulant and two polymeric coagulants ([1] polymeric coagulant 1, [2] inorganic + polymeric coagulant 1, and [3] polymeric coagulant 2) to treat sludge of various characteristics. The inorganic coagulant is injected into the sludge feed tank, polymeric coagulant 1 into the outlet side of measuring tank and polymeric coagulant 2 into the mixing tank.

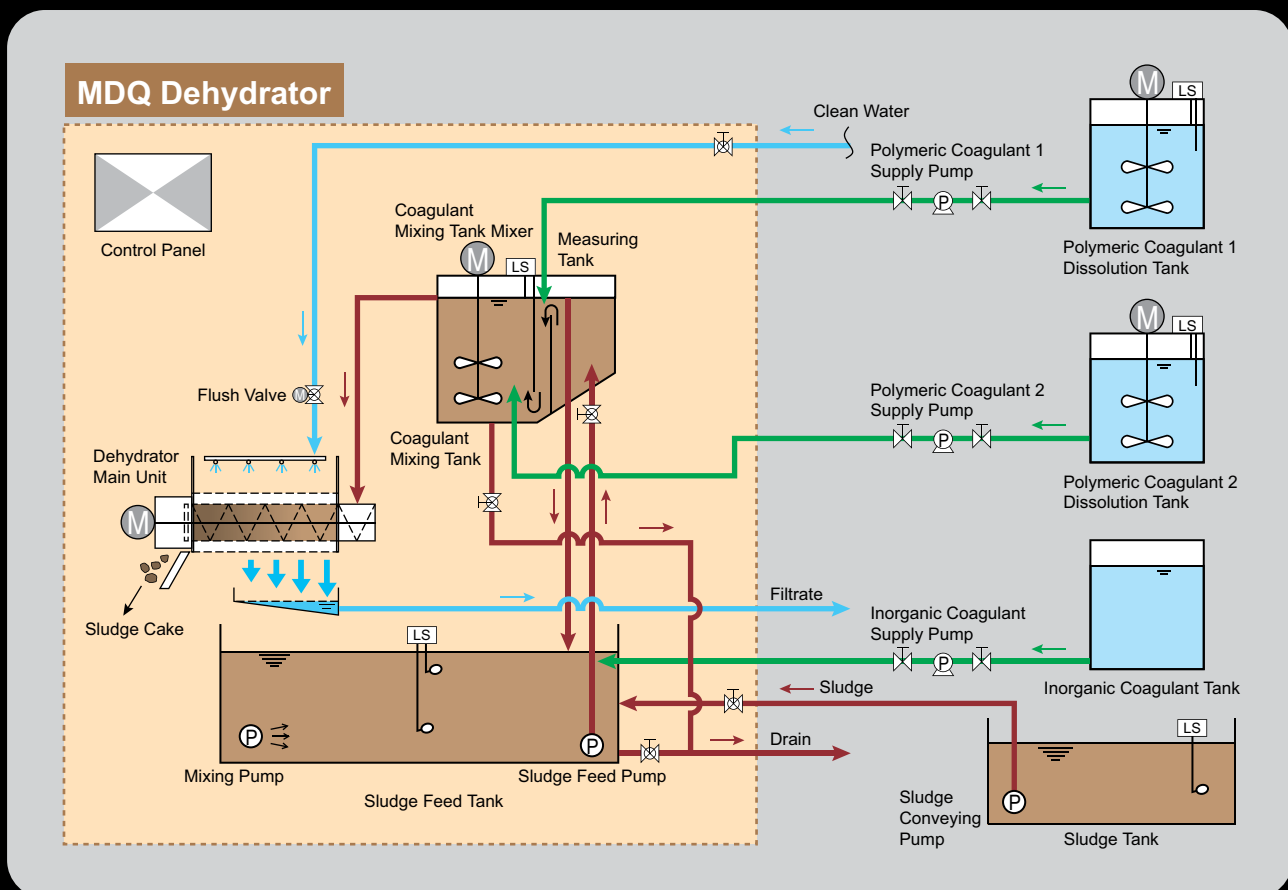

# MDC Flow Sheet



The sludge is fed into the measuring tank in the MDC dehydrator by a sludge feed pump (not included) in the sludge tank. A predetermined amount of sludge is measured in the measuring tank and naturally flows into the coagulant mixing tank; the excess feed is naturally returned to the sludge tank. In the coagulant mixing tank, liquid polymeric coagulant is added to the sludge; flocking then occurs owing to the mixing action. After flock generation, the sludge overflows the coagulant mixing tank and naturally flows into the dehydrator main unit, where the filtrate is separated and the resultant dehydrated cake is delivered out of the dehydrator.

The coagulant to be used can be selected from combinations of two polymeric coagulants ([1] polymeric coagulant 1 and [2] polymeric coagulant 2) to treat sludge of various characteristics. Polymeric coagulant 1 is injected into the outlet side of measuring tank and polymeric coagulant 2 into the mixing tank.

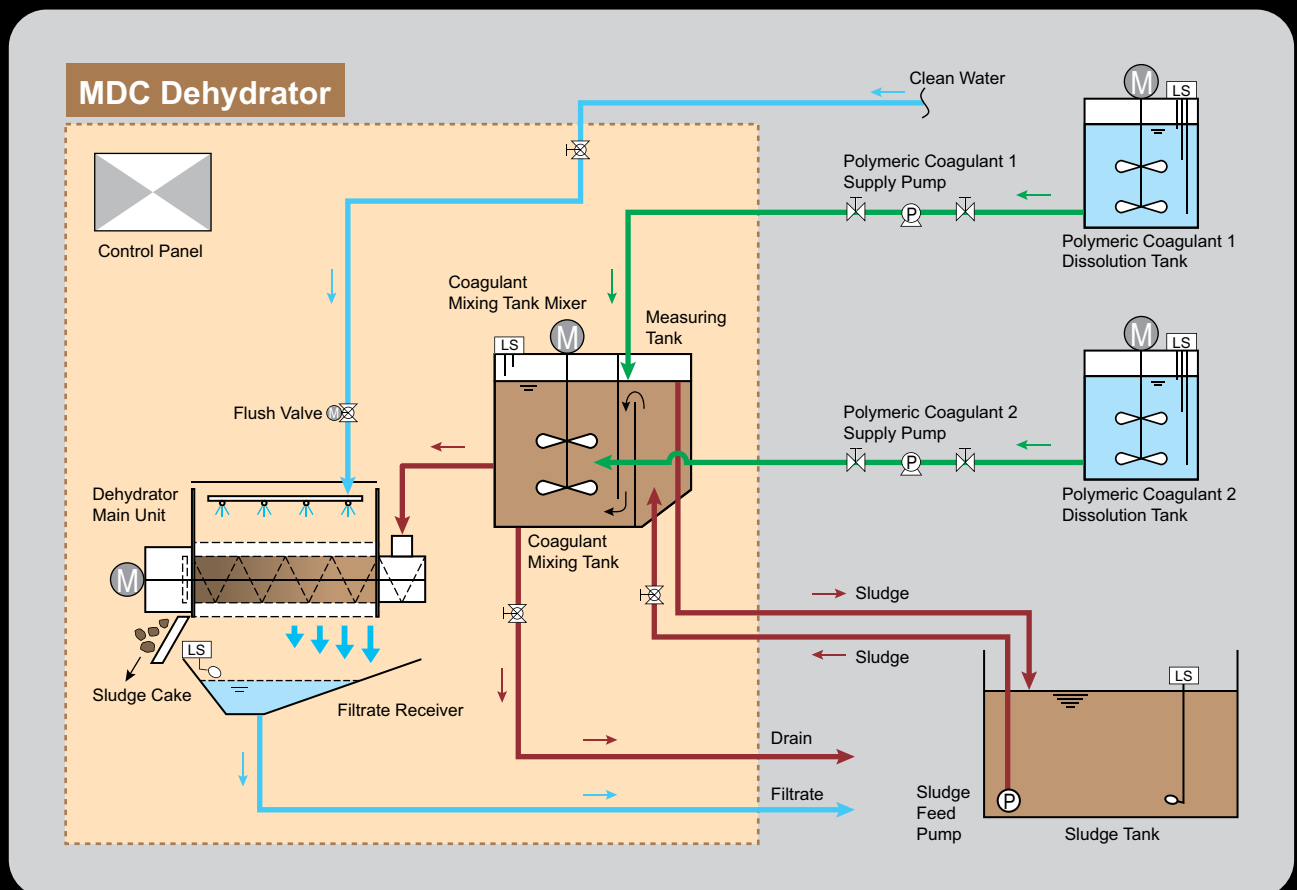

# Specifications

Model	Treating Capacity (lbsDS/h)	Motor Output (hp)	Dimension (inches)				Weight (lbs)	
			Screw Shaft	Length	Width	Height	Dry	Operating
MDQ-101	6.5 - 13	0.8	φ 4" X 1	70 7/8	35 7/16	70 7/8	181	454
MDQ-102	13 - 26	0.9	φ 4" X 2	70 7/8	35 7/16	70 7/8	227	522
MDQ-103	20 - 40	1.3	φ 4" X 3	72 13/16	43 5/16	70 7/8	318	703
MDQ-104	26.5 - 53	1.7	φ 4" X 4	82 11/16	59 1/16	80 11/16	408	885
MDQ-105	33 - 66	1.8	φ 4" X 5	82 11/16	59 1/16	80 11/16	454	953
MDQ-201	20 - 40	1.4	φ 8" X 1	104 5/16	47 1/4	80 11/16	318	726
MDQ-202	39.5 - 79	1.7	φ 8" X 2	104 5/16	47 1/4	80 11/16	408	862
MDQ-203	59.5 - 119	2.4	φ 8" X 3	104 5/16	59 1/16	80 11/16	544	1157
MDQ-204	79 - 158	3.2	φ 8" X 4	110 1/4	82 11/16	80 11/16	726	1610
MDQ-205	99 - 198	3.9	φ 8" X 5	110 1/4	82 11/16	80 11/16	816	1746
MDC-351	79 - 158	1.3	φ 14" X 1	148 7/16	44 7/8	78 15/16	590	830
MDC-352	158 - 316	2.5	φ 14" X 2	154 3/4	57 1/2	79 15/16	1043	1501
MDC-353	238 - 476	4.2	φ 14" X 3	166 1/8	71 1/4	86 5/8	1497	2195

- The treating capacity will vary depending on the characteristics and concentration of sludge.
- Applicable sludge must be organic and have an ignition loss (VTS = Volatile Total Solids) of more than 60% and a concentration (TS) of 0.5 to 2.0%.
- The motor output means the total motor output of the MDQ/MDC dehydrator that includes the dehydrator main unit, but does not cover motor output of the sludge conveying/feed pump, chemical feed equipment, etc.
- The sludge conveying/feed pump, chemical feed equipment, chemical feed pump, etc. outside the MDQ/MDC dehydrator are not included.

## Model Number Designation



# Dimensions

## MDQ

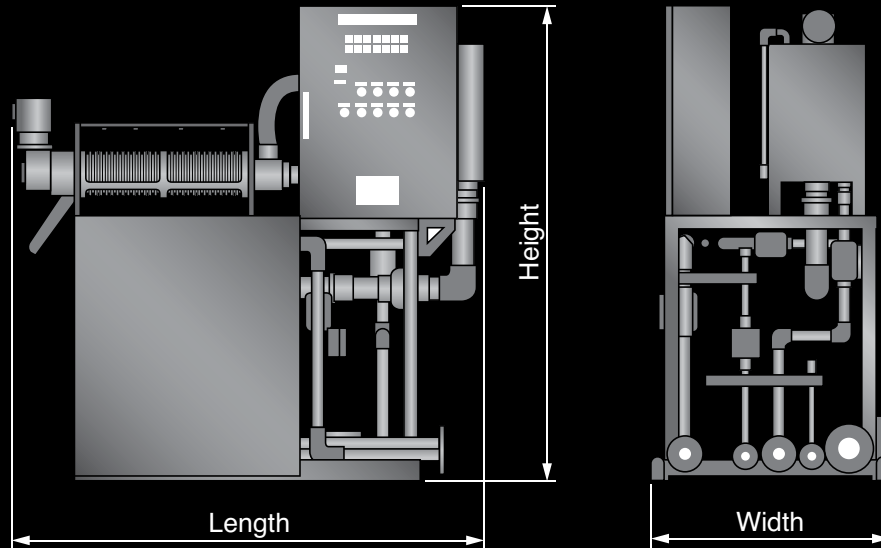

## MDC

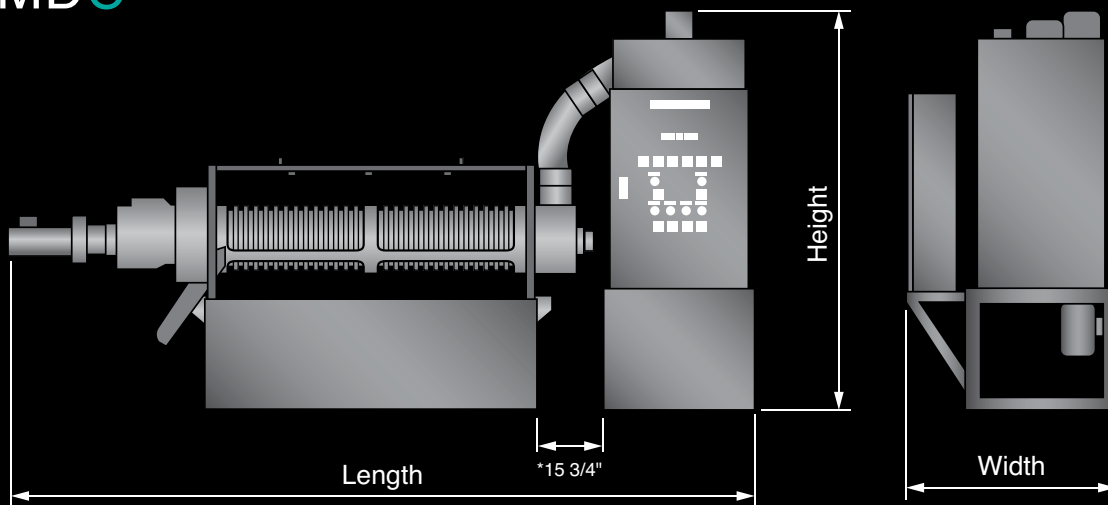

\* On MDC-series, the screw is independent of the coagulant mixing tank.  
 To fully develop the performance of dehydrator, install the dehydrator main unit and the coagulant mixing tank unit on common ground. (Distance 15.75")



# Multi-Disc Dehydrators

Breakthrough multi-disc dehydrator that consists of both resin and stainless steel discs and is free from clogging



JD

# Features

01

## Energy-saving & Compact Design

The JD-series features energy-saving construction designed to dehydrate sludge by “gravity filtration + compression.” The equipment is of compact unitized construction with a flush water tank and control panel mounted on a common base, and therefore can be readily installed in very limited floor space.

02

## Automatic Operation

Operators can begin automatic operations of the dehydrator and related accessories by simply and easily operating the included control panel.

03

## Self-cleaning Mechanism

The filtration surface consists of a multiplicity of discs and a self-cleaning mechanism, therefore it never clogs and the equipment can run continuously.

04

## Capable of Treating Oily Sludge

The equipment can stably dehydrate even sludge that contains high oil content. The dehydrator is an optimum solution for treating oily sludge such as DAF froth at food processing plants, which filter cloth systems and centrifugal separation processes cannot readily handle. Thus, the equipment boasts a higher solid capture rate.

05

## Capable of Treating Low to High Concentration Sludge

The dehydrator can handle sludge of various concentrations in a range as great as 0.5 to 5.0%.

06

## Small Amount of Flush Water and Low Maintenance

Because the “filtering rollers” are constructed so as to never clog, flushing is not needed in order to restore the original filtration performance. Only flushing of sludge that oozes from the filtering rollers is necessary. The amount of flush water needed is minimal, and routine maintenance work is not needed.

07

## Inhibition of Secondary Pollution

The dehydrator main unit features a semi-enclosed construction, and runs at an extremely low speed, therefore sludge does not splatter from the equipment. The dehydrator is of eco-friendly design that generates low noise and vibrations, and emits virtually no odors.



## Structure

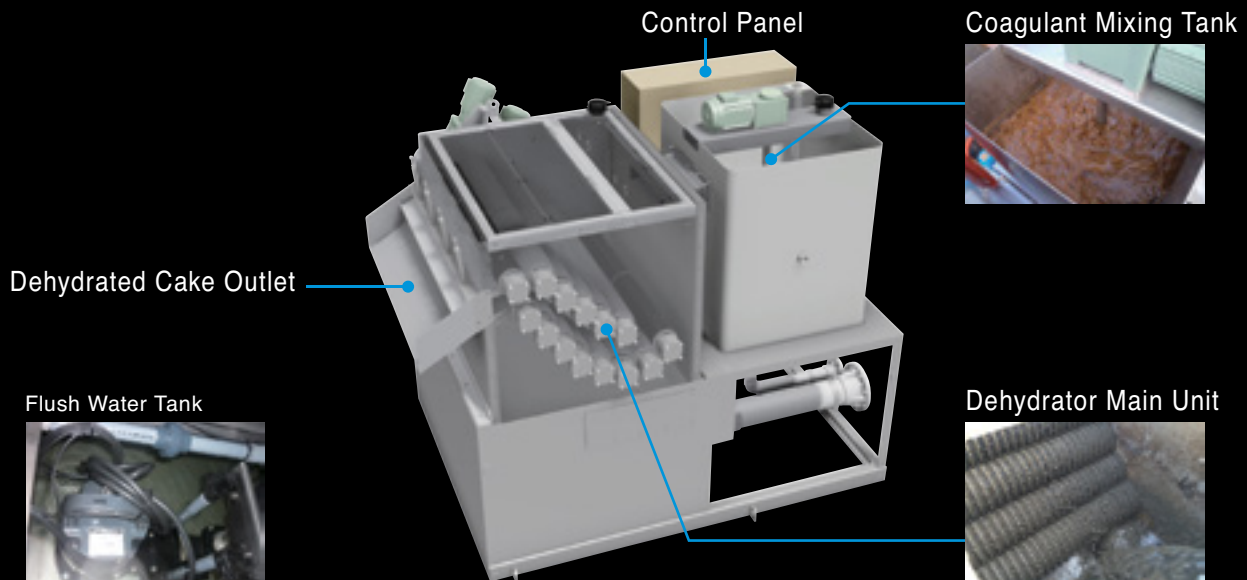

## Mechanical Principle

The main unit of the multi-disc dehydrator contains multiple rows of "filtering rollers" arranged in two (upper and lower) tiers. Each filtering roller consists of a multiplicity of thick resin discs, small thin stainless steel discs and large thin stainless steel discs. A slit is formed between neighboring discs so that only water drains out. The larger discs of the filtering roller engage with the neighboring filtering roller, causing the slits to be constantly cleaned. Thus, the dehydrator exhibits stable sludge treatment capacity. [Patented]

The gaps between the upper and lower tiers of the filtering rollers narrow from the sludge infeed inlet to the dehydrated cake outlet; therefore the volume of sludge is moderately compressed. In short, the coagulated sludge fed into the dehydrator main unit is conveyed toward the outlet side as the filtering rollers rotate, during which the sludge is compressed and water drains through the slits, so the sludge is efficiently dehydrated.

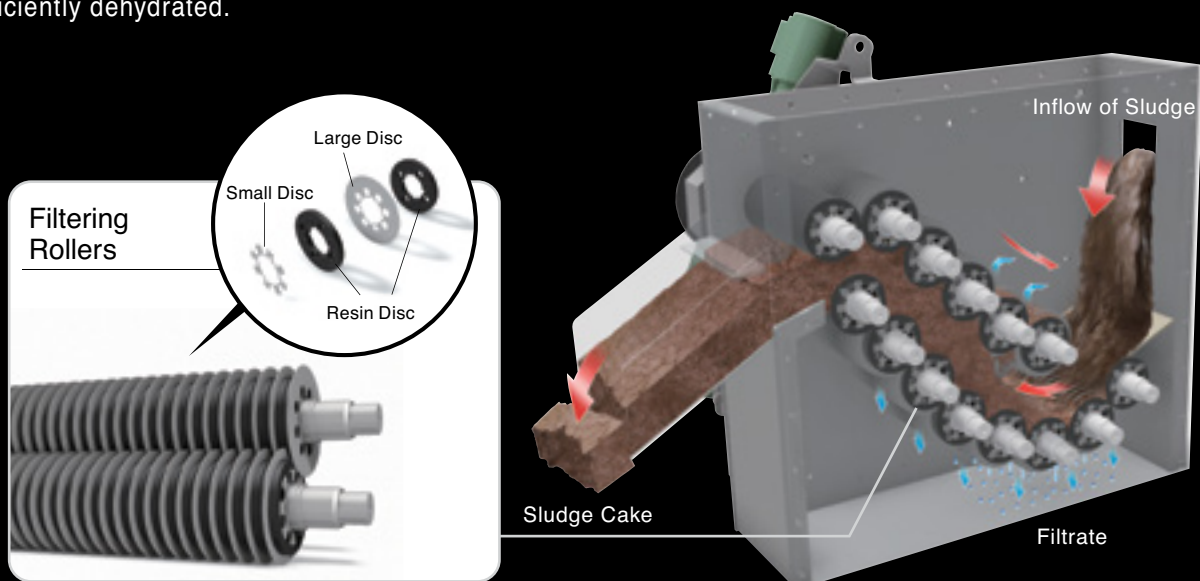

# JD Flow Sheet



The sludge is fed into the measuring tank in the JD dehydrator by a sludge feed pump (not included) in the sludge tank. A predetermined amount of sludge is measured in the measuring tank and naturally flows into the coagulant mixing tank; the excess feed is naturally returned to the sludge tank. In the coagulant mixing tank, liquid polymeric coagulant is added to the sludge; flocking then occurs owing to the mixing action. After flock generation, the sludge overflows the coagulant mixing tank and naturally flows into the dehydrator main unit, where the filtrate is separated and the resultant dehydrated cake is delivered out of the dehydrator.

The coagulant to be used can be selected from combinations of two polymeric coagulants ([1] polymeric coagulant 1 and [2] polymeric coagulant 2) to treat sludge of various characteristics. Polymeric coagulant 1 is injected into the outlet side of measuring tank and polymeric coagulant 2 into the mixing tank.

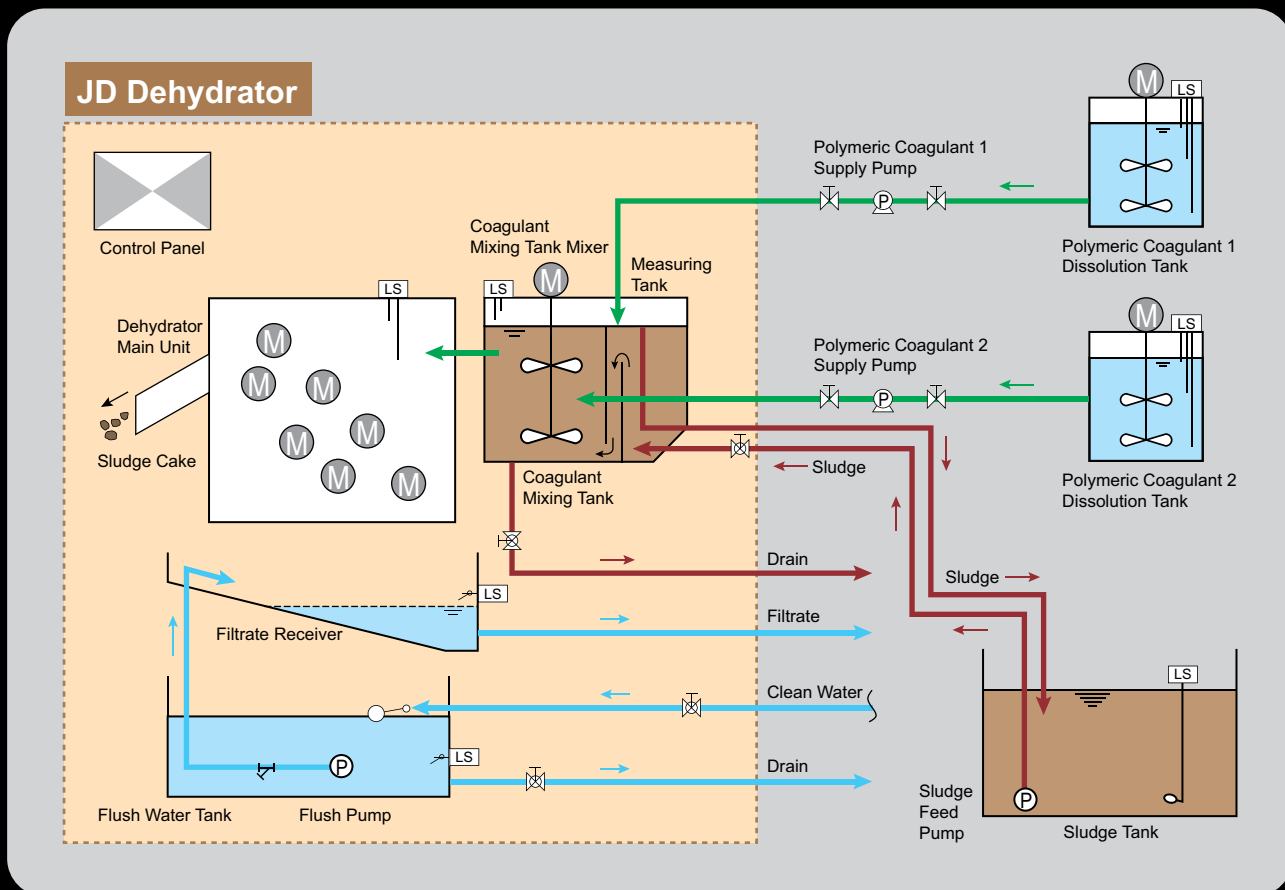

# Specifications

Model	Treating Capacity (lbsDS/h)	Motor Output (hp)	Dimension (inches)				Weight (lbs)	
			Width of Filtering Rollers	Length	Width	Height	Dry	Operating
JD-500	26.5 - 88	2.2	19 11/16	86 7/8	40 3/4	71 15/16	499	726
JD-750	39.5 - 132	2.5	29 1/2	88 1/4	50 9/16	72	590	885
JD-1000	53 - 176	3.5	39 3/8	91 9/16	60 7/16	72	680	1066

- The treating capacity will vary depending on the characteristics and concentration of the sludge. Typical treating capacity per 39 3/8" wide filtering roller are 88 lbsDS/h for excess sludge, 110 lbsDS/h for wastewater and sewage treatment sludge, and 132 lbsDS/h for DAF froth and livestock waste sludge. It is recommended to select a model with adequate allowance.
- The motor output means the total motor output of the motors mounted in the unit, but does not cover the motor output of the sludge supply pump, polymeric coagulant mixing equipment, etc.
- The sludge feed pump, chemical injection equipment, chemical injection pump, etc. outside the JD dehydrator are not included.

# Dimensions

JD

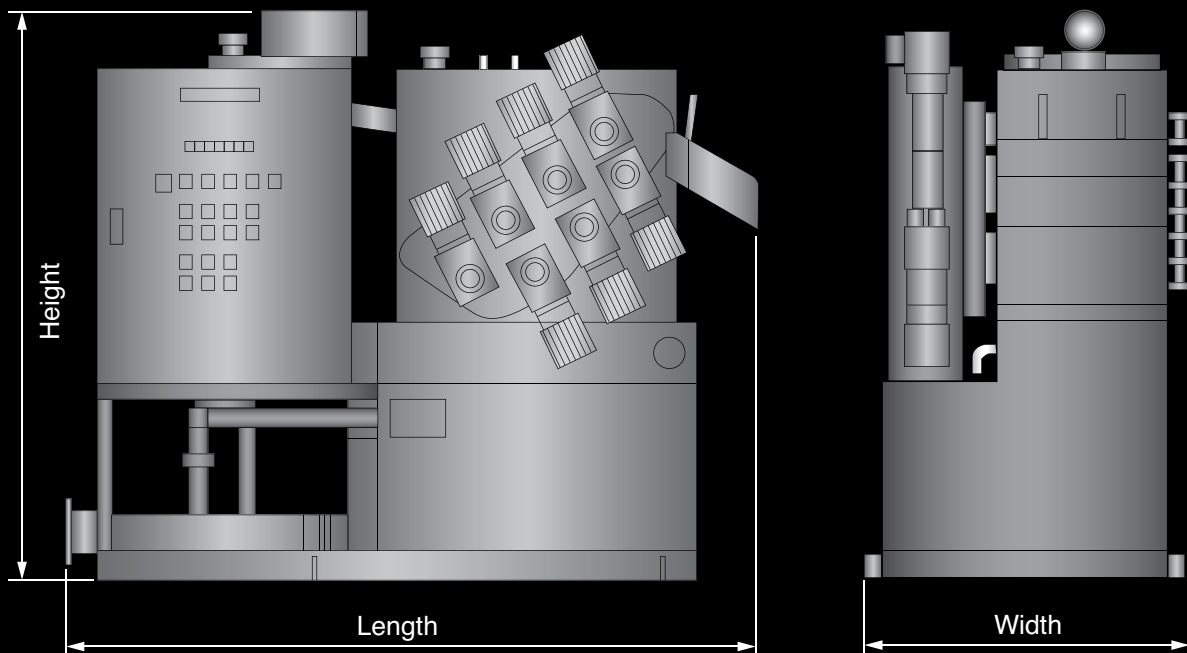

[www.tsurumipump.com](http://www.tsurumipump.com)



Find us @tsurumiamerica

We reserve the right to change the specifications and designs for improvement without prior notice.

**Tsurumi (America), Inc.**  
1625 Fullerton Ct  
Glendale Heights, IL 60139  
Toll-Free: 888-878-7864  
Fax: 630-793-0146  
[info@tsurumiamerica.com](mailto:info@tsurumiamerica.com)

Your Dealer

CAT. IA134-A\_TAI\_V1