



FTS300 & FTS400

FTS-Series Positive Displacement Pumps

Fluid Transfer Solutions

- ▶ **FTS300** - 3" • Flow Rates up to 320 GPM
- ▶ **FTS400** - 4" • Flow Rates up to 600 GPM

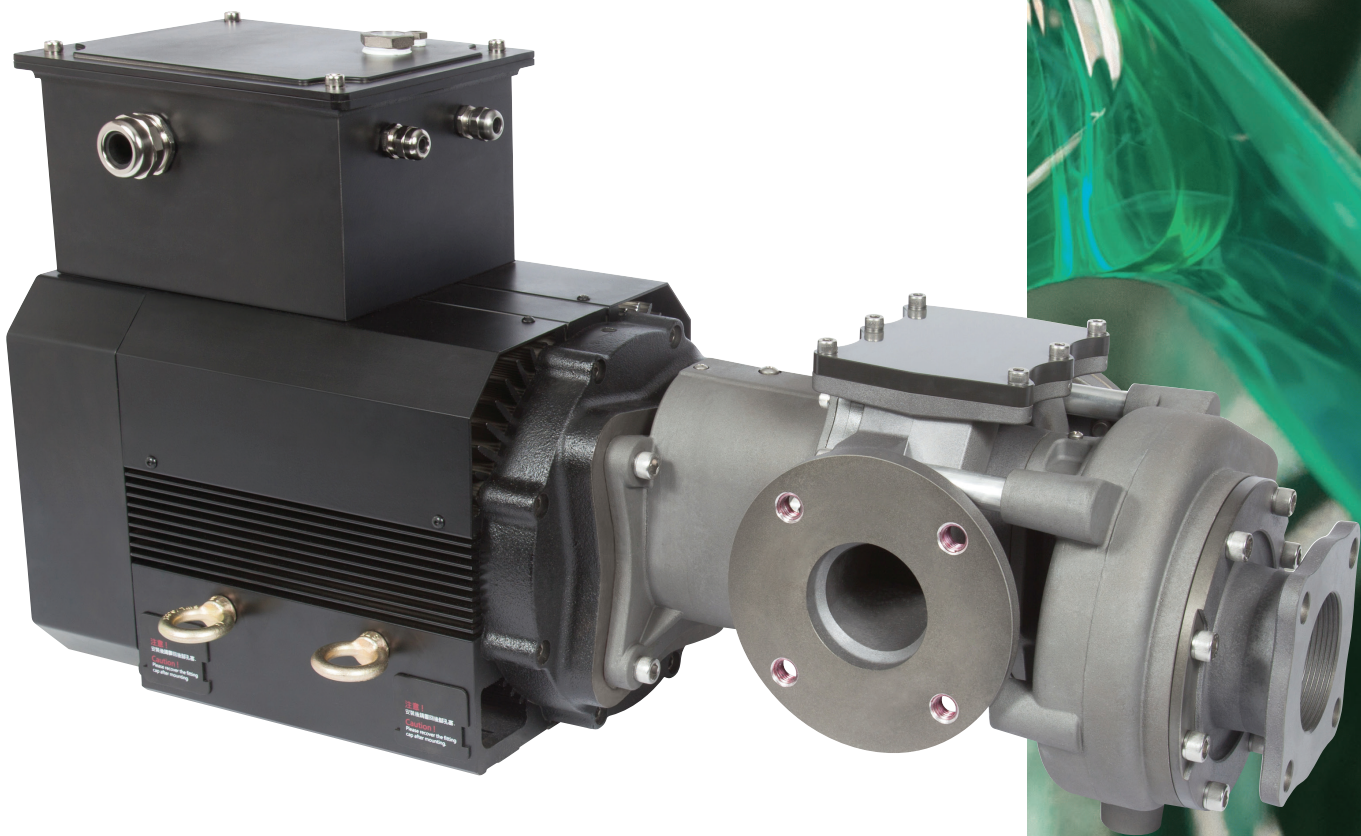

- ▶ **Continuous Dry-Run Capable**
- ▶ **Self-Priming and High Suction Lift**
- ▶ **Lowest NPSHr in its class**
- ▶ **Resistant to Cavitation**
- ▶ **Reversible Flow**

IMPROVED PERFORMANCE FOR LONGER LIFE

High-performance 3" & 4" fluid transfer pumps which excel in pumping high vapor pressure fluids

Copyright © 2020 Liquiflo, Inc.
All rights reserved. 06-2020

A Look Inside Advanced Fluid Transfer

THE NEXT GENERATION IN FLUID TRANSFER SOLUTIONS

Liquiflo's **FTS-Series Fluid Transfer Pumps** combine advanced engineering and manufacturing capabilities offering a pumping solution for stationary, mobile, and high vapor-pressure fluid applications.

FTS-300: Flows up to 320 GPM

FTS-400: Flows up to 600 GPM

Unique Two-stage Design

The first stage centrifugal impeller provides an effective boost to the suction capability of the second-stage positive displacement lobe pump. This particular design allows the **FTS-Series** pumps to resist cavitation while delivering high-volume flow *even when* pumping fluids with high vapor pressure. This design enables the pump to generate high lift, and allows the pump to run dry for extended periods of time.

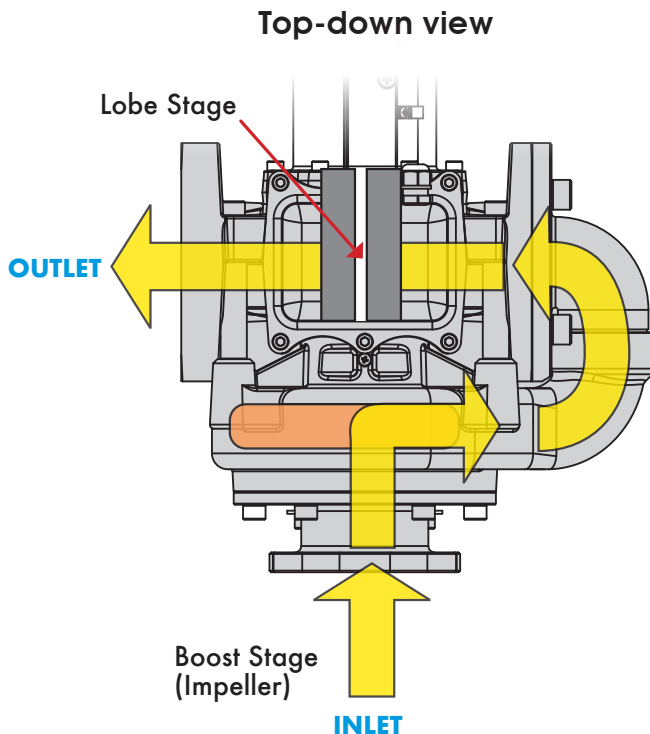

The **FTS-Series**

Fluid Transfer Pumps are high-performance 3" & 4" positive displacement lobe pumps with an inlet boosting centrifugal impeller, transferring fluids up to 600 GPM (2,27 LPM) at 140 PSI (9.65 bar)

- ▶ **Dry Run Capable:** Pump design and material choices allow for continuous dry run between wetted pumping cycles.
- ▶ **Self-Priming:** FTS-Series pumps will quickly self prime and are not subject to vapor lock.
- ▶ **Cavitation Resistant:** Boost impeller significantly decreases NPSHr, reducing cavitation.
- ▶ **Reversible Flow:** Can be operated bi-directionally, benefiting from the centrifugal boost only in the "forward" flow direction.
- ▶ **Small Footprint:** 40% lighter and shorter than competitive pumps.

1 **TRI-LOBE ROTORS AND SHAFTS**

- Engineered materials and coatings extend pump life and allow pump to run dry without damage.
- Spring-loaded wiper blades ensure a tight seal with pump body developing high volumetric efficiency and enabling high suction and lift.

FLUIDS



Crude Oils



Lubricants



Petroleum Contact
and Salt Waters



Diesel and
Biodiesel Fuels



Gasoline

FTS-Series • 3" & 4" Pump Models

IMPROVED PERFORMANCE FOR LONGER LIFE

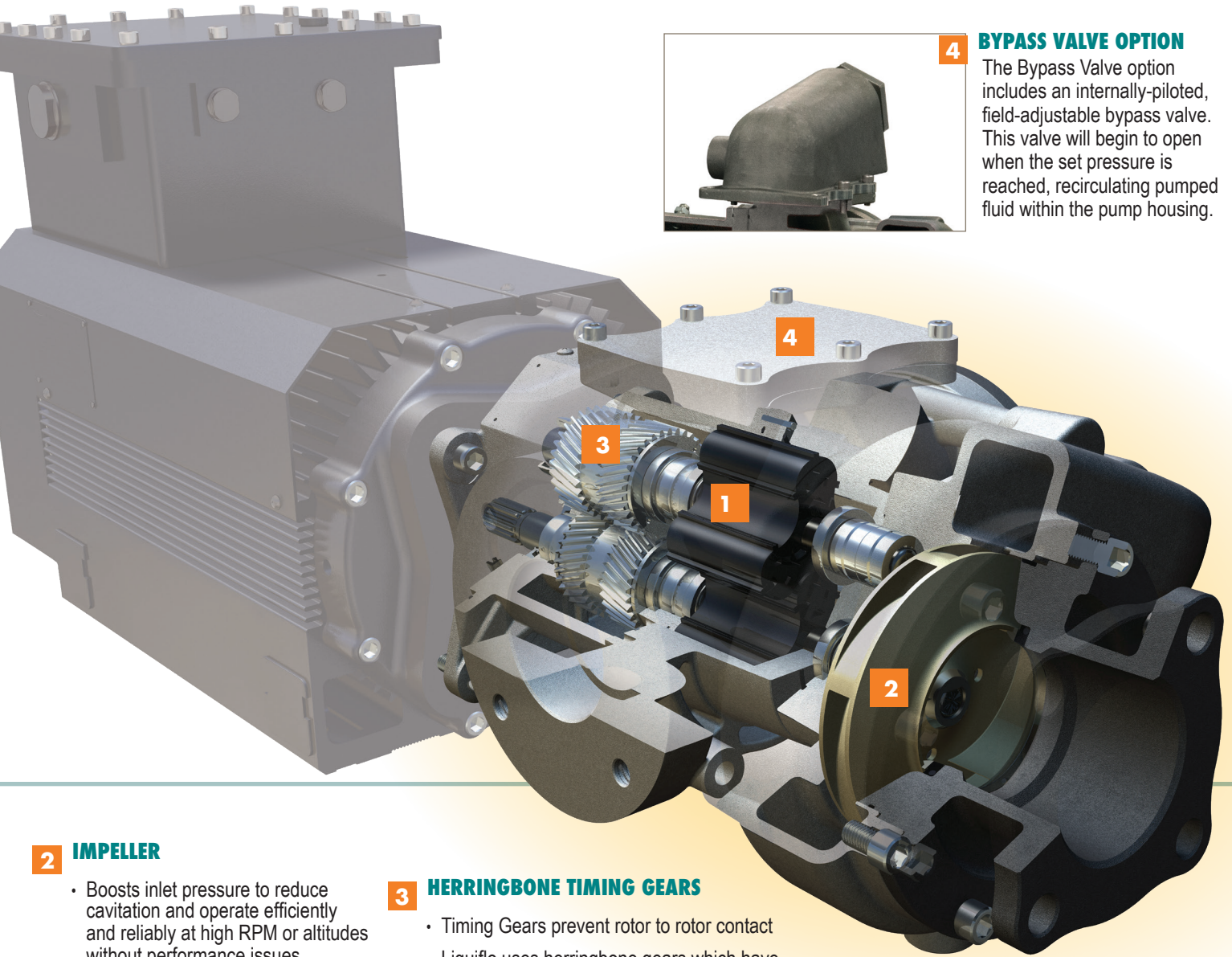

4 BYPASS VALVE OPTION

The Bypass Valve option includes an internally-piloted, field-adjustable bypass valve. This valve will begin to open when the set pressure is reached, recirculating pumped fluid within the pump housing.

2 IMPELLER

- Boosts inlet pressure to reduce cavitation and operate efficiently and reliably at high RPM or altitudes without performance issues.
- Thrust-balanced design minimizes wear

3 HERRINGBONE TIMING GEARS

- Timing Gears prevent rotor to rotor contact
- Liquiflo uses herringbone gears which have high-torque carrying capability and eliminate thrust loads common in helical gears

Liquiflo[®]

TRANSFER



Aviation Fuels



Truck



Railcar



Tank to Tank

FTS-Series Fluid Transfer Systems



Flow

20 to 600 GPM
(75 to 2271 LPM)



Pressure

0 to 140 PSID
(0 to 9.65 bar)



Viscosity

<0.5 to 2,200 cSt
(<20 to 10,300 SSU)



Temperature

14°F to 250°F
(-10°C to 120°C)

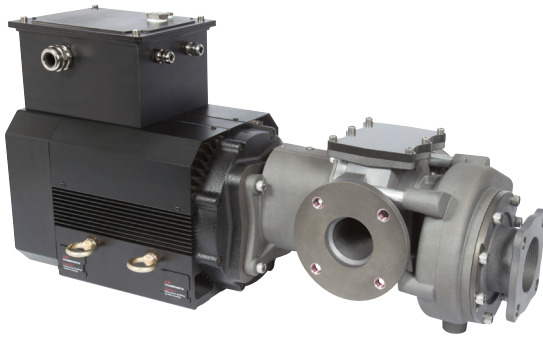

Electric Motor System

Designed for stationary and process applications. This system offers a high capacity with a small footprint.



RVP Electric Motor System

Designed for high vapor pressure fluids (up to RVP16) in applications where meter reading is essential (e.g. custody transfer). Resists vapor lock while maintaining a high-flow rate.

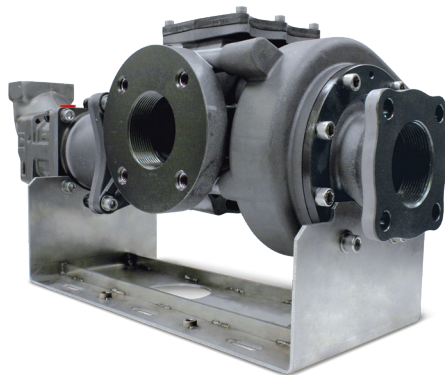

Hydraulic Motor System

Designed for truck-mount applications. This system offers powerful high-flow in a compact and lightweight package making it ideal for truck transfer.



Diesel Engine System

Designed for mobile and skid-mounted applications. Provides portable and dependable service where electricity is not available.

Copyright © 2020 Liquiflo, Inc.
All rights reserved. 06-2020

Liquiflo[®]

tel.
908.518.0777

fax.
908.518.1847

sales@liquiflo.com

443 North Ave
Garwood
New Jersey
07027
USA

Since 1972,
Liquiflo pumps
have handled
thousands
of process
fluids.