

# UNRESTRICTED FLOW.

## Lowest Fluid Loss.

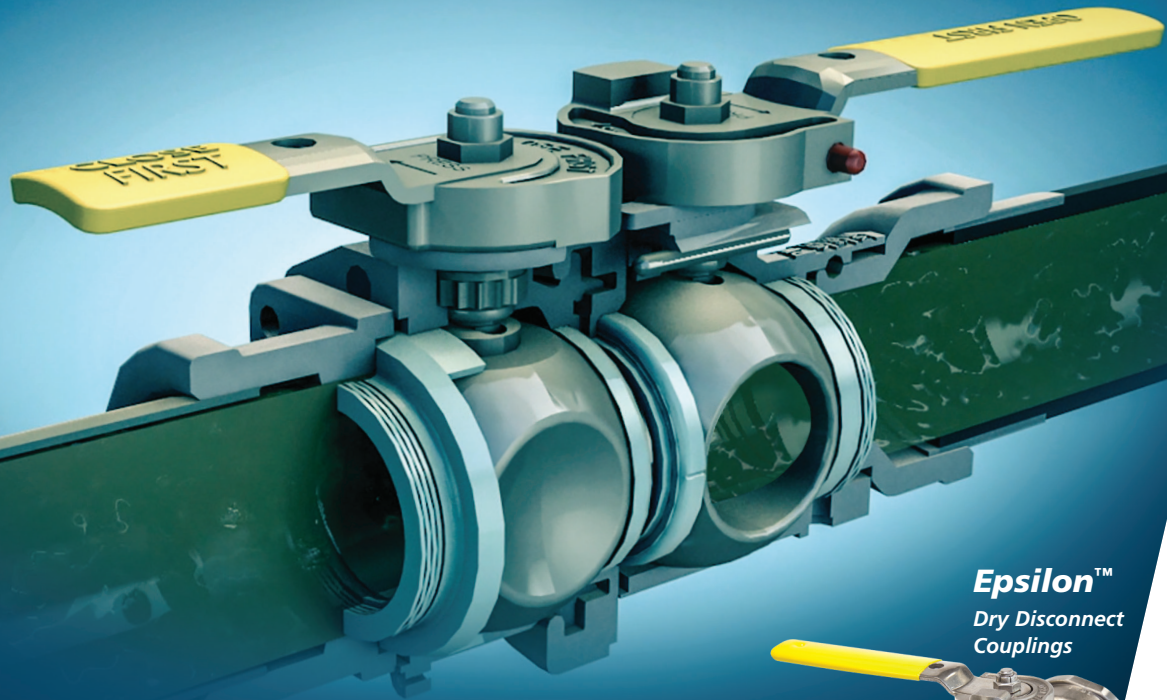

**Epsilon™**  
Dry Disconnect  
Couplings

### Superior Design Delivers Great Performance

Featuring an innovative double ball-valve system, *Epsilon™* Dry Disconnect Couplings deliver the lowest product loss in the industry. A tactical balance of an unrestricted flow path and double shutoff reliability makes *Epsilon™* the safest and most efficient coupling system in the world.

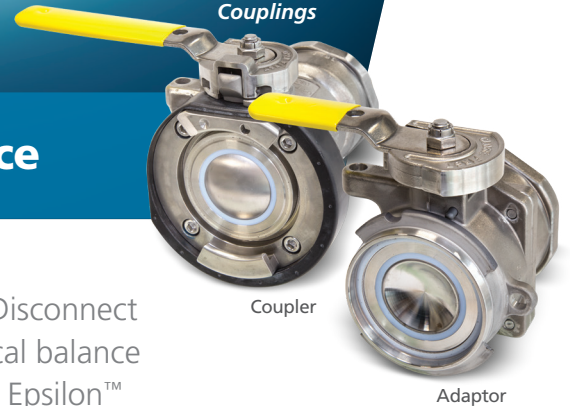

#### Features & Benefits:

- **LOWEST FLUID LOSS**, driven by the innovative unique double ball-valve system, ensures the lowest product loss in the industry.
- **UNPARALLELED SAFETY** with multiple interlocks that eliminate unintentional disconnects and chemical releases that could threaten worker safety and the environment.
- **FULL FLOW** with unrestricted flow path. No turbulence!
- **OPTIMAL DEFENSE** against cross-contamination with optional keyed couplings that mechanically lock out and isolate transfer lines.
- **ENGINEERED FOR EASY OPERATION** and maintenance with no special tools needed for seal replacements.
- **316 STAINLESS** or **HASTELLOY® CONSTRUCTION** for critical, aggressive, corrosive fluids.
- **1", 2" AND 3" SIZES**
- **PRESSURES UP TO 435 PSI (30 BAR)**



[opw-es.com](http://opw-es.com)

**ENGINEERING | WHAT'S NEXT**

# Epsilon™ Coupler

## Ball-Valve Style Design

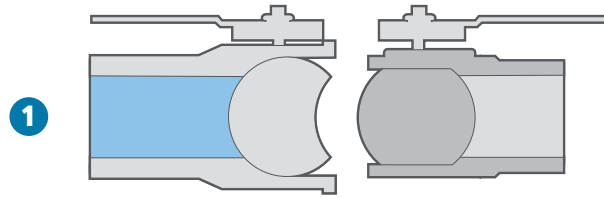

### Lowest fluid loss at disconnection

Ball-Valve Design connects with Convex Ball Surface Seats with Concave Ball to prevent product from getting trapped in cavity. The result is minimal product loss.

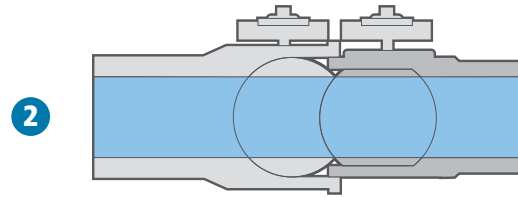

### Unrestricted flow when connected

Liquid transfers through adaptor and coupling without any restrictions to the flow.

## Ordering Information

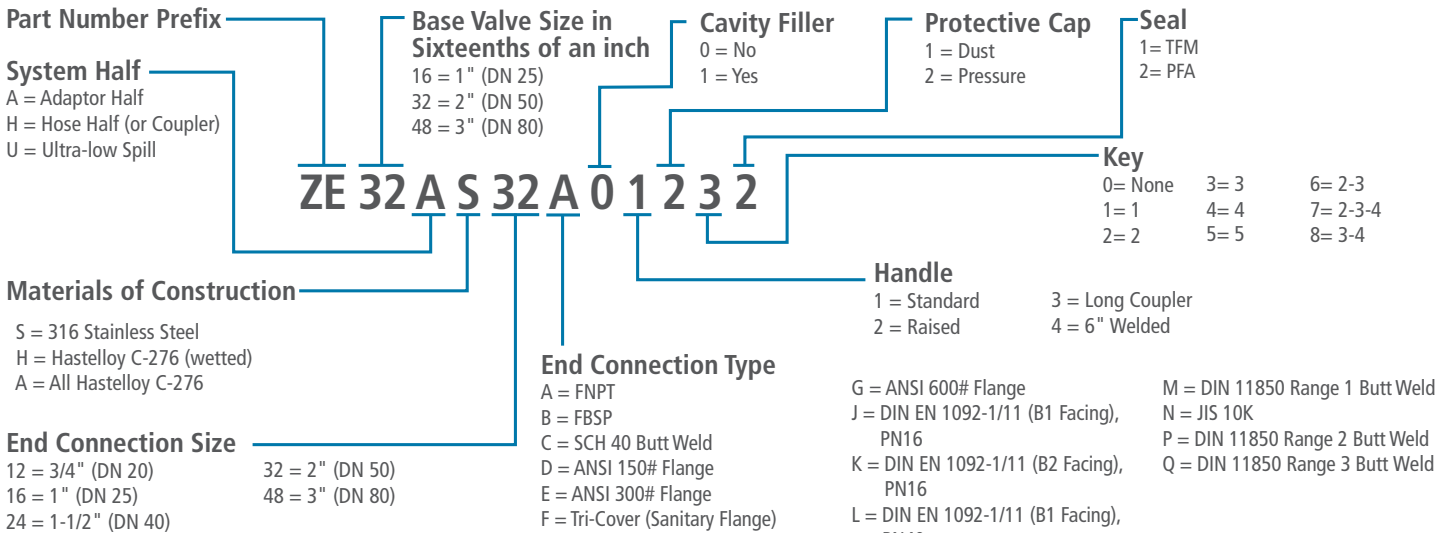

Availability of styles, sizes and materials may vary depending on swivel configurations. Consult OPW Customer Service regarding your exact requirements.

Valve Size	Port Size	Maximum Emissions	Flow Rate GPM L/min	C <sub>v</sub>	Max Working Pressure psi (bar)	Weight - lbs (kg)		Temp = °F (°C)	
						Adapter	Coupler	Min	Max
1-inch	3/4", 1", DN 20 or DN 25 Port	<25 ppm	50 (189)	42	435 (30)	2.7 (1.2)	3.0 (1.4)	-22° (-30°)	450 (230)
2-inch	1-1/2", 2", DN 40 or DN 50 Port	<25 ppm	150 (568)	160	435 (30)	4.0 (1.8)	6.0 (2.7)	-22° (-30°)	450 (230)
3-inch	3" or DN 80 Port	<25 ppm	300 (1135)	240	360 (25)	16.0 (7.3)	19.0 (8.6)	-22° (-30°)	450 (230)