

500-E Series

HYDRAULIC METERING PUMPS



Where Innovation Flows

Neptune™

Neptune™ 500-E Series Hydraulic Metering Pumps offers an economical alternative to the standard 500 Series pumps or a packed plunger pump that includes the Neptune Variable Oil By-Pass™. The Variable Oil By-Pass stroke adjustment allows improved valve performance over variable linkage designs.

FEATURES AND BENEFITS

- Economical alternative to standard 500 Series
- Max capacity up to 34 gph (113 L/h)
- Max pressure up to 1,100 psi (77 bar)
- Materials of construction: 316SS, PVDF, PVC



OPTIONS

- Capacity control options include electric stroke length adjustment and variable speed drives

500-E Series Hydraulic Metering Pumps SELECTION CHART

Standard Motor 1/3hp-1ph-115VAC-60c-TEFC

MODEL	PISTON DIAMETER INCHES (MM)	STROKES PER MIN AT 60 HZ (50 HZ)	MATERIALS OF CONSTRUCTION	CAPACITY AT 100 PSI (7 BAR) 60 HZ (50 HZ)		MAX PRESSURE PSI (BAR)	SHIPPING WEIGHT LB. (KG)
				GPH	L/H		
515-E-N3 515-E-N5 515-E-AR 515-E-N8	1/2 (13)	117 (97)	316SS PVC Hypochlorite PVDF	3 (2.5)	11.3 (9.4)	1,100 (77) 150 (11) 150 (11) 150 (11)	59 (27)
520-E-N3 520-E-N5 520-E-N8	11/16 (18)	72 (60)	316SS PVC PVDF	2 (1.7)	7.5 (6.3)	700 (49) 150 (11) 150 (11)	59 (27)
522-E-N3 522-E-N5 522-E-AR 522-E-N8	11/16 (18)	72 (60)	316SS PVC Hypochlorite PVDF	4 (3.3)	15.1 (12.6)	700 (49) 150 (11) 150 (11) 150 (11)	59 (27)
525-E-N3 525-E-N5 525-E-AR 525-E-N8	11/16 (18)	117 (97)	316SS PVC Hypochlorite PVDF	7 (5.8)	26.5 (22.1)	900 (63) 150 (11) 150 (11) 150 (11)	59 (27)
527-E-AR	11/16 (18)	144 (120)	Hypochlorite	8.6 (7.2)	32 (26.7)	150 (11)	59 (27)
532-E-N3 532-E-N5 532-E-N8	1-1/16 (27)	72 (60)	316SS PVC PVDF	11 (9.2)	41.6 (34.7)	350 (25) 150 (11) 150 (11)	59 (27)
535-E-N3 535-E-N5 535-E-N8	1-1/16 (27)	117 (97)	316SS PVC PVDF	18 (15)	68 (56.7)	350 (25) 150 (11) 150 (11)	59 (27)
547-SE-N3* 547-SE-N5*	1-3/16 (30)	144 (120)	316SS PVC	29 (23.3)	110 (91)	200 (14) 150 (11)	65 (29)
547-DE-N3**	1-3/16 (30)	144 (120)	316SS	29 (23.3)	110 (91)	200 (14)	85 (39)
548-SE-N3*	1-3/16 (30)	176 (147)	316SS	34 (28.3)	128 (106.7)	200 (14)	85 (39)

* Simplex Economy Model Style
** Duplex Economy Model Style

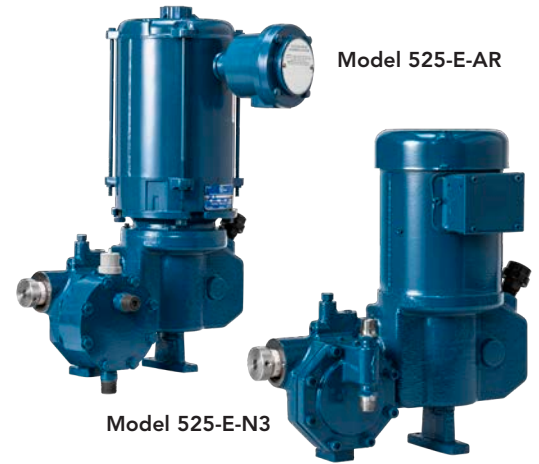

CROSS SECTIONAL VIEWS

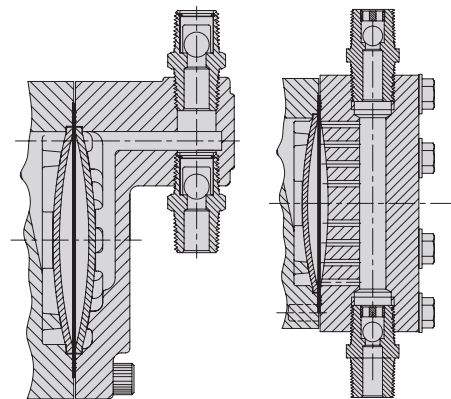

N3 Head Assembly

N5 & N8 Head Assembly

MATERIALS OF CONSTRUCTION

MATERIAL CODE	PUMP HEAD	CHECK VALVE BODY	CHECK VALVE BALL	DIAPHRAGM
N3	316SS	316SS	316SS	PTFE
N5	PVC*	PVC*	Glass***	PTFE
AR**	PVC*	PVC*	Glass***	PTFE
N8	PVDF	PVDF	Ceramic	PTFE

* PVC head pumps are satisfactory for temperatures to 125°F (52°C).
** PVC head with air release valve for sodium hypochlorite service.
*** Special materials available for services not compatible with glass.

MATERIAL CODE	DIMENSIONS INCHES (MM)			CONNECTION (NPT)
	A	B	C	
N3	2-1/2 (63.5)	3-5/8 (92.1)	2-3/4 (69.9)	3/8
N5	1-7/16 (36.5)	7-3/8 (187.3)	3/4 (19.1)	1/2
N8	1-7/16 (36.5)	7-3/8 (187.3)	3/4 (19.1)	1/2

All Models (except 527 & 547)

For Models 527 & 547:

A = 1-7/8" for N3 Models

A = 3/4" for N5 Models

See Bulletin DP-1100 for Models 527 & 547 mounting dimensions

DIMENSIONS

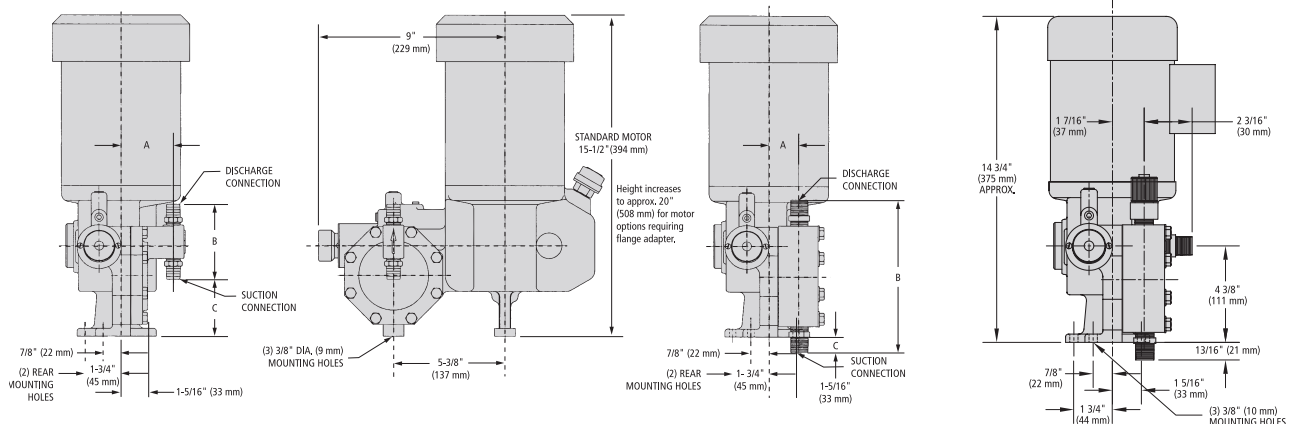

Available Chemical Feed Systems With 500-E Series Pumps

TOP-MOUNTED CHEMICAL FEED SYSTEM



System includes:

1. 500-E Series Pump
2. Model ET-P Tank (includes):
 - 50 gallon self-supporting polyethylene tank
 - Molded polyethylene cover
 - Suction piping and PVC foot valve strainer
3. Model L-2-300 Agitator (optional)

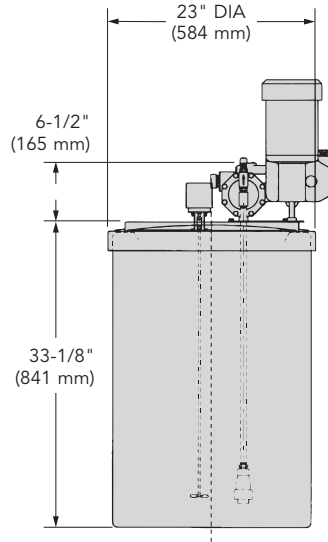

BOTTOM-MOUNTED CHEMICAL FEED SYSTEM



System includes:

1. 500-E Series Pump
2. Model 50PT-300 Tank (includes):
 - 50 gallon polyethylene tank in steel support
 - Molded polyethylene cover
 - PVC suction piping, PVC valve and iron strainer
3. Model L-1-300 or A-1-301 Agitators (optional)

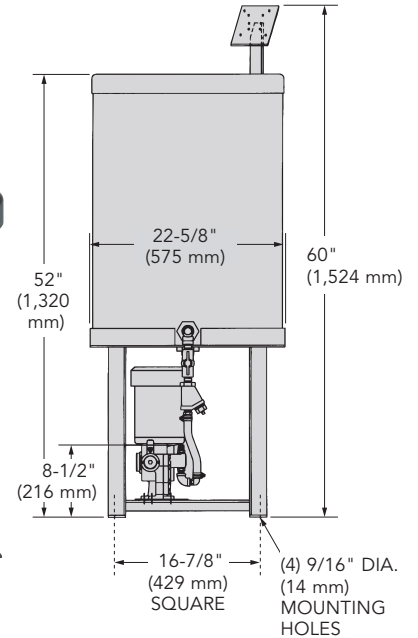

AGITATORS

Neptune also offers a line of economically priced agitators for use with the tanks shown above:

MODEL	MOTOR DESCRIPTION	MOUNTING STYLE	MATERIAL OF CONSTRUCTION
L-1-300	1/20hp-1-115-TEFC	Direct Mount* Vert. to Lid	316SS
L-2-300	1/20hp-1-115-TEFC	Direct Mount* Vert. to Lid	316SS
A-1-301	1/4hp-1-115-TEFC	Direct Mount*	316SS

*Mounting plate supplied on tank.

L-1-300 Agitator

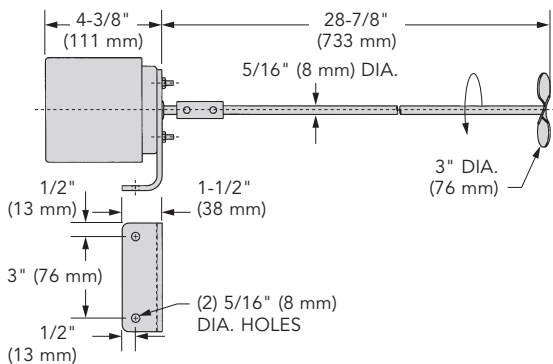

L-2-300 Agitator

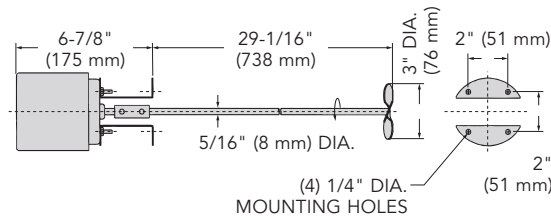

A-1-301 Agitator

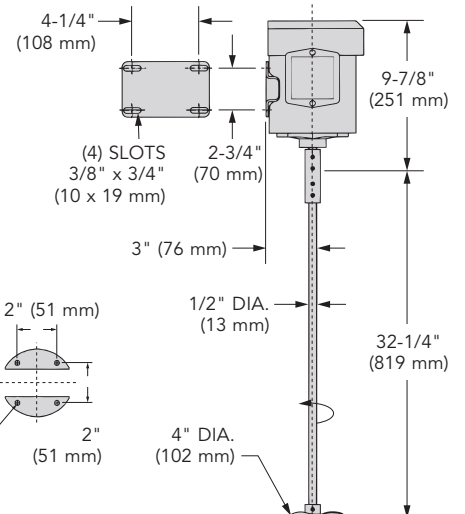

Additional Solutions by Neptune

BACK PRESSURE VALVES

Back pressure valves are adjustable to a maximum of 50 psi (3.5 bar). Ensure the set pressure is maintained at the pump outlet port (discharge) to assure accurate metering and prevent siphoning. Required accessory when pumping to a low-pressure injection point below the tank level or when pumping from a bulk tank with a high head pressure.



- Available in PVC, 316SS, PVDF and C-20 materials
- Standard sizes include 1/2" through 1-1/2" options

CALIBRATION COLUMNS

Provide a fast, easy economical way to check the flow rate of a chemical metering pump.

- Standard sizes include 100, 250, 500, 1000 and 4000 ml options



CORPORATION STOPS & QUILLS

Used for injecting chemicals pumped into turbulent-flow zone of high-pressure water or steam lines to provide a more rapid, uniform dispersion of injected chemical. Corporation stops allow injection quills to be inserted or removed without having to drain or shut down the system.

- Available in CPVC, PVDF, 316SS and C-20 materials



PRESSURE RELIEF VALVES

Relief valves protect piping and system from overpressure.



- Available in PVC, 316SS, PVDF and C-20 materials
- Standard sizes include 1/2" through 1-1/2" options

EZE-GRAB PLATFORM

Molded polyethylene base provides elevated platform for use indoors or outdoors. Handles allow the pump to be moved easily.



SAMPLE COOLERS

Cool hot water or steam samples for easy handling and effective sample collection. Suitable for use on hot water, saturated steam or super-heated steam services.

- Available in 316SS and Inconel materials



PULSATION DAMPENERS

Remove the pulsating flow caused by a pump's reciprocating action, ensuring a smooth, laminar flow.



- Available in PVC, polypropylene, 316SS, and C-20 (with FKM or EPDM bladders) materials

30 GALLON MINI TANK

Neptune offers a line of completely packaged chemical feed systems, with or without containment.



BY-PASS FEEDERS

Neptune By-Pass Feeders are a convenient method of introducing treatment chemicals into closed water recirculation systems. Neptune By-Pass Feeders are ideal for treating hot and chilled closed water recirculation loops used in heating and air conditioning systems, process heating and cooling or large engine water jackets.

- Available with and without legs
- Max pressure up to 300 psi (20.7 bar)



For more information on these additional solutions, visit us at psgdoover.com/neptune.

Neptune

PSG

22069 Van Buren Street

Grand Terrace, CA 92313-5651 USA

P: +1 (909) 422-1730 • F: +1 (909) 783-3440

psgdoover.com/neptune

Distributed By:

Where Innovation Flows



DP-500E-19

© 2019 PSG, a Dover company

NPT-10110-C-01

Neptune reserves the right to modify the information and illustrations contained in this document without prior notice. This is a not-contractual document.