



MARCH PUMPS

1819 PICKWICK AVE., GLENVIEW, IL 60026-1306, U.S.A
 PHONE: (847) 729-5300 - FAX: (847) 729-7062
 WWW.MARCHPUMP.COM

DESCRIPTION:

Series 8 are centrifugal magnetic drive pumps, eliminating the need for a shaft seal. Pumps are serviceable with an adjustable wrench. Screws should be tightened in sequence & uniformly. Do not over tighten the screws or you may crush the plastic housing bosses. See the parts list for a breakdown of parts.

Model Abbreviations: C: Polypropylene, K: Kynar, S: Stainless Steel

OPERATION:

Pumps are not self-priming, lack a suction lift, and thus require a **flooded suction**. Pumps **cannot be run dry** because the impeller requires the liquid being pumped for lubrication. The direction of motor rotation should be clockwise when facing the inlet of the pump. For liquids with a specific gravity greater than water, have a higher viscosity, or for elevated temperatures, a trimmed impeller may be necessary. For application assistance, contact March Pump.

ELECTRICAL:

TE-8-MD pumps are dual voltage 230/460, 3 phase 60 Hz and dual voltage 190/380, 3 phase 50 Hz, TEFC. Motors are totally enclosed fan cooled and are U.L. listed as well as rated for continuous operation. All motors have a conduit box for electrical connections.

ASSEMBLY & DISASSEMBLY:

When replacing impeller bushings in the field, the plastic bushings must be bored to size after they have been pressed into the impeller. Bore to 0.630/0.632 I.D. The carbon & ceramic bushings are to finished size and do not require boring. When attaching the drive magnet to the motor shaft, position the face of the drive magnet 3/8 inch below the face of the motor bracket.

LIMITED WARRANTY:

March pumps are guaranteed only against defects in workmanship or materials for a period of one year from date of manufacture pumping water. For the complete warranty and to register online go to www.marchpump.com/warranty-registration

TE-8C-MD, TE-8K-MD, TE-8S-MD

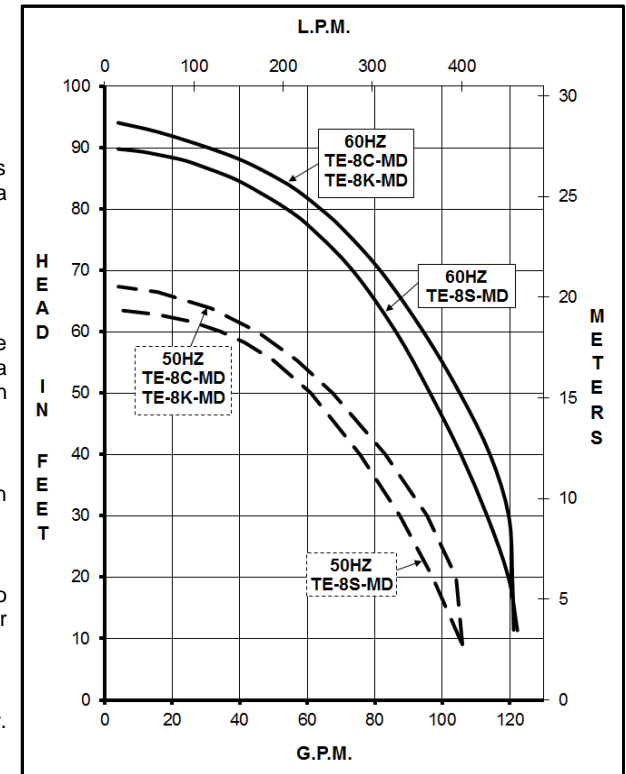

SPECIFICATIONS	TE-8C-MD										TE-8K-MD										TE-8S-MD																																						
Product #	0157-0008-0100										0157-0008-0200										0157-0030-0100																																						
Inlet - Outlet	2" MPT - 1-1/2" MPT										2" MPT - 1-1/2" MPT										2" MPT - 1-1/2" MPT																																						
Max Internal Pressure	50 psi (344 kPa)										75 psi (517 kPa)										200 psi (1378 kPa)																																						
Max Liquid Temperature	190 °F (87 °C)										200 °F (93 °C)										250 °F (121 °C)																																						
MODEL	60 Hz										50 Hz										Height		Width		Length		Packed Weight																																
	Max Flow		Max Head			ELECTRICAL					Max Flow		Max Head			ELECTRICAL					Inches	cm	Inches	cm	Inches	cm	lbs	kg																															
	gpm	lpm	ft	psi	m	Ph	V	A	Hp	kW	Rpm	gpm	lpm	ft	psi	m	Ph	V	A	Hp	kW	Rpm																																					
TE-8C-MD	120	454	95	41.2	29	3	230	7.8	3	2.2	3450	105	400	65.6	28.4	20	3	190	9.2	3	2.2	2850	10.86	27.5	12.73	32.3	24.68	62.6	142	64.41																													
							460	3.9										380	4.6																																								
TE-8K-MD	120	454	95	41.2	29	3	230	7.8	3	2.2	3450	105	400	65.6	28.4	20	3	190	9.2	3	2.2	2850	10.86	27.5	12.73	32.3	24.68	62.6	142	64.41																													
							460	3.9										380	4.6																																								
TE-8S-MD	120	454	90	39	27.4	3	230	12.6	5	3.7	3450	105	400	63.3	27.4	19.3	3	190	15	5	3.7	2850	10.86	27.5	12.73	32.3	24.68	62.6	180	81.5																													
							460	6.3										380	7.5																																								

All specifications & data are based on pumping water & are intended as a guideline only. Specifications may vary with different motors.

PARTS LIST

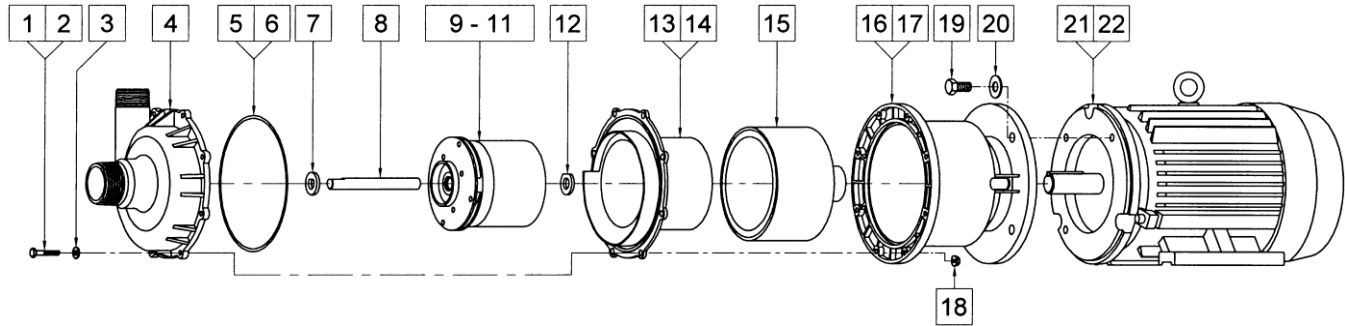

Materials in Contact with Solution: TE-8C-MD: Polypropylene/Carbon Filled, Viton, Teflon/Ryton/Carbon, Ceramic
TE-8K-MD: Kynar/Carbon Filled, Viton, Carbon, Ceramic

#	DESCRIPTION	TE-8C-MD	TE-8K-MD	SIZE (Inches)	QTY.	TE-8C-MD	TE-8K-MD
1	Screw		Stainless	1/4-20 x 1-1/2 Lg.	8	0153-0011-1000	
2	Screw (Used w/Item #17) (Option)		Stainless	1/4-20 x 1-1/4 Lg.	8	0157-0036-1000	
3	Washer		Stainless	1/4 ID x 5/8 OD	8	0157-0023-1000	
4	Pump Housing	Polypropylene	Kynar		1	0157-0007-1000	0157-0052-1000
5	"O" Ring		Viton	0.157 CS x 7.244 ID	1	0157-0011-1000	
6	"O" Ring (Option)		Viton/Teflon	1/8 CS x 7-1/2 OD	1	0157-0032-1000	
7	Thrust Washer (Front)		Ceramic		1	0157-0001-1000	
8	Shaft		Ceramic		1	0157-0002-1000	
9	Impeller w/Ryton Bushing	Polypropylene	Kynar (Option)		1	0157-0004-0200	0157-0050-0200
10	Impeller w/Carbon Bushing	Polypropylene (Option)	Kynar		1	0157-0004-0500	0157-0050-0500
11	Impeller w/Mica Teflon Bushing	Polypropylene (Option)	Kynar (Option)		1	0157-0004-0700	0157-0050-0700
12	Thrust Washer (Rear)		Ceramic		1	0157-0009-1000	
13	Rear Housing	Polypropylene			1	0157-0006-1000	
14	Rear Housing		Kynar		1		0157-0053-1000
15	Drive Magnet				1	0157-0005-0100	
16	Motor Bracket		Plastic		1	0157-0100-1000	
17	Motor Bracket (Option)		Metal		1	0157-0008-0000	
18	Lock Nut (Serrated)		Stainless	1/4-20	8	0156-0053-1000	
19	Screw		Stainless	1/2-13 x 1 Lg.	4	0160-0031-1000	
20	Washer		Stainless	1/2 ID x 1-1/4 OD	4	0160-0032-1000	
21	TEFC Motor, 3 HP, 230/460 V, 3 Phase, 50/60 Hz				1	0157-0012-1000	
22	TEFC Motor, 5 HP, 230/460 V, 3 Phase, 50/60 Hz (Option)				1	0157-0065-1000	
W	Wet End Kit	1,3,4,5,7,8,9,12,13,18	1,3,4,5,7,8,10,12,14,18		1	0157-0085-0100	0157-0086-0100

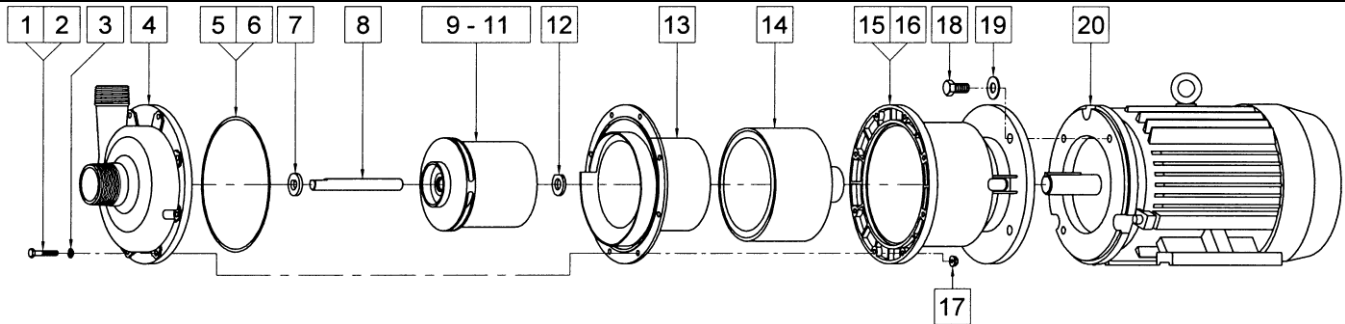

Materials in Contact with Solution: 316 Stainless Steel, Viton, Carbon, Ceramic

#	DESCRIPTION	TE-8S-MD	SIZE (Inches)	QTY.	TE-8S-MD
1	Screw	Stainless	1/4-20 x 1-1/2 Lg.	8	0153-0011-1000
2	Screw (Used w/Item #16) (Option)	Stainless	1/4-20 x 1-1/4 Lg.	8	0157-0036-1000
3	Lock Washer (Split)	Stainless	1/4	8	0157-0037-1000
4	Pump Housing	316 Stainless		1	0157-0030-0001
5	"O" Ring	Viton	0.157 CS x 7.244 ID	1	0157-0011-1000
6	"O" Ring (Option)	Viton/Teflon	1/8 CS x 7-1/2 OD	1	0157-0032-1000
7	Thrust Washer (Front)	Ceramic		1	0157-0001-1000
8	Shaft	Ceramic		1	0157-0002-1000
9	Impeller w/Carbon Bushing	316 Stainless		1	0157-0029-0500
10	Impeller w/Ryton Bushing (Option)	316 Stainless		1	0157-0029-0200
11	Impeller w/Mica Teflon Bushing (Option)	316 Stainless		1	0157-0029-0700
12	Thrust Washer (Rear)	Ceramic		1	0157-0009-1000
13	Rear Housing	316 Stainless		1	0157-0028-0001
14	Drive Magnet			1	0157-0005-0100
15	Motor Bracket	Plastic		1	0157-0100-1000
16	Motor Bracket (Option)	Metal		1	0157-0008-0000
17	Lock Nut (Serrated)	Stainless	1/4-20	8	0156-0053-1000
18	Screw	Stainless	1/2-13 x 1 Lg.	4	0160-0031-1000
19	Washer	Stainless	1/2 ID x 1-1/4 OD	4	0160-0032-1000
20	TEFC Motor, 5HP, 230/460V, 3 Phase, 50/60 Hz			1	0157-0065-1000

NOTE: Contact Factory for other materials and/or parts not listed such as explosion proof and special voltage motors.

0157-0021-1000 R19