



**FEATURES**

- Corrosion resistant construction
- Cast iron body
- Thermoplastic impeller and cover.
- Upper sleeve and lower heavy duty ball bearing construction.
- Motor is permanently lubricated for extended service life.
- Powered for continuous operation.
- All ratings are within the working limits of the motor.
- Quick disconnect power cord, 10' and 20' standard lengths, heavy duty 16/3 SJTW with NEMA three prong, 115 or 230 volt grounding plug.
- Complete unit is heavy duty, portable and compact.
- Mechanical seal is carbon, ceramic, BUNA and stainless steel.
- Stainless steel fasteners

**PS**

**SUBMERSIBLE SEWAGE PUMP**



### APPLICATIONS

Specially designed for the following uses:

- Residential sewage systems
- Heavy duty sump/dewatering
- Water transfer

### SPECIFICATIONS

#### Pump - General:

- Discharge: 2" NPT
- Temperature: 104°F (40°C) maximum, continuous when fully submerged.
- Solids handling: 2" maximum sphere.
- Automatic models include a float switch.
- Manual models available.

#### PS4 Pump:

- Maximum capacity: 110 GPM
- Maximum head: 23' TDH

#### PS5 Pump:

- Maximum capacity: 130 GPM
- Maximum head: 27' TDH

### MOTOR

#### General:

- Single phase
- 60 Hertz
- 115 and 230 volt
- Built-in thermal overload protection with automatic reset.
- Class B insulation
- Oil-filled design
- High strength carbon steel shaft

#### PS4 Motor:

- .40 HP, 3400 RPM
- PSC design

#### PS5 Motor:

- .50 HP, 3400 RPM
- PSC design

### AGENCY LISTINGS



Tested to UL 778 and CSA 22.2 108 Standards  
By Canadian Standards Association  
File #LR38549

### MODEL INFORMATION

Order No.	HP	Volts	Amps	Minimum Circuit Breaker	Phase	Float Switch Style	Cord Length	Discharge Connection	Minimum Basin Diameter	Maximum Solids Size	Shipping Weight lbs/kg
PS41M	0.4	115	10.0	20	1	Manual / No Switch	10'	2"	18"	2"	40 / 18.1
PS41P1						Piggyback Float Switch					
PS41MF						Manual / No Switch					
PS41P1F		Piggyback Float Switch									
PS42MF		230	5	15		Manual / No Switch	20'				
PS42P1F						Piggyback Float Switch					
PS51M	0.5	115	13.0	20	1	Manual / No Switch	10'	2"	18"	2"	40 / 18.1
PS51P1						Piggyback Float Switch					
PS51MF						Manual / No Switch					
PS51P1F		Piggyback Float Switch									
PS52MF		230	6.5	15		Manual / No Switch	20'				
PS52P1F						Piggyback Float Switch					

### PERFORMANCE CHARTS

These charts show actual system performance with friction loss factored in for various discharge pipe lengths. Calculations and performance based on a system with 2" PVC, schedule 40 plastic pipe (C150), (4) 90° elbows, (1) check valve and (1) shut-off valve. Wastewater requires a minimum scouring velocity of 21gpm for 2" pipe. Shaded areas do not provide min. scouring velocity - use only for gray water with no solids.

#### PS4

Pipe Length	GPM									
	Vertical Head (Feet)									
	2	4	6	8	10	12	14	16	18	20
25	96	88	82	74	65	54	43	33	24	14
50	83	77	70	63	56	47	38	30	22	13
75	74	68	62	56	49	42	35	28	21	13
100	67	62	57	51	45	39	33	26	19	12
150	57	53	48	44	39	34	29	23	17	11
200	51	47	43	39	35	31	26	22	16	10
250	46	43	39	36	33	28	24	21	16	10
300	43	39	37	34	30	27	23	19	15	9

#### PS5

	4	6	8	10	12	14	16	18	20	22
25	105	99	91	84	75	65	55	45	35	25
50	90	85	78	71	63	56	48	40	32	24
75	80	74	69	62	57	50	44	37	30	22
100	72	67	62	57	52	46	40	34	28	21
150	61	58	54	49	45	40	35	31	25	18
200	54	51	48	44	40	36	32	28	23	17
250	50	47	44	40	37	34	30	26	21	16
300	46	43	40	37	34	31	28	24	20	15

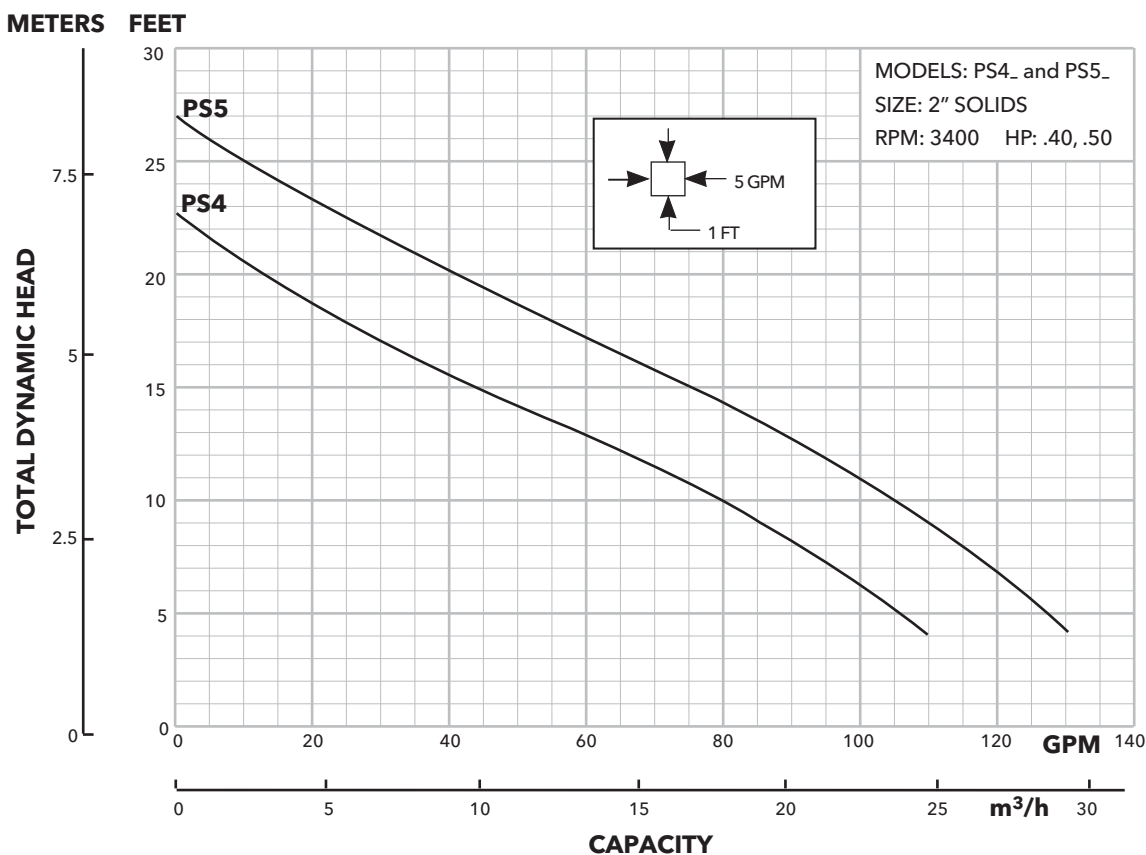

## DIMENSIONS

(All dimensions are in inches. Do not use for construction purposes.)

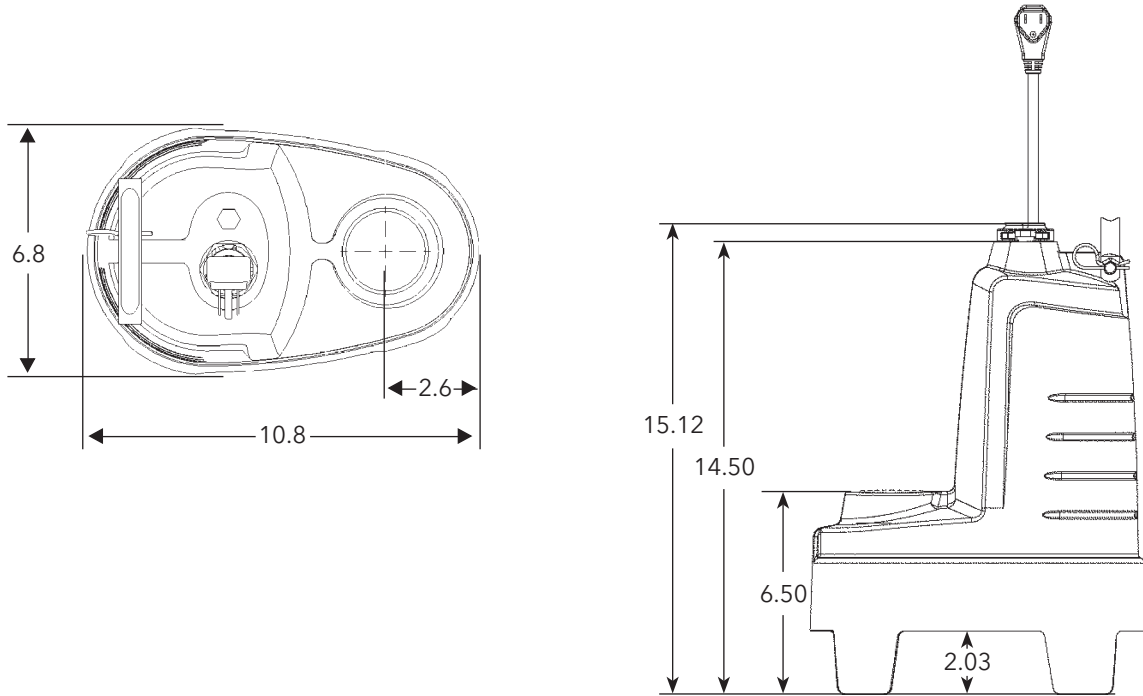

Xylem Inc.  
2881 East Bayard Street Ext., Suite A  
Seneca Falls, NY 13148  
Phone: (866) 325-4210  
Fax: (888) 322-5877  
[www.gouldswatertechnology.com](http://www.gouldswatertechnology.com)

Goulds is a registered trademark of Goulds Pumps, Inc. and is used under license.  
© 2016 Xylem Inc. BPS R1 September 2016