



FEATURES

Impeller: Cast iron multi-vane vortex style, with rip vane on the back edge of the impeller for removing stringy solids.

V model designation for vortex impeller

Casing: Cast Iron construction with large unobstructed passage way to pass large solids.

Efficient air-filled motor

Stand: Optional stand for mounting without slide rail configuration. Part number: 7482200

Dual Mechanical Seals:

Up to 6.4 HP: For standard pumps, Tungsten Carbide vs. Ceramic seal faces standard on outer seals. Carbon vs. Ceramic standard on inner seals.

Over 6.4 HP: Tungsten Carbide vs. Tungsten Carbide faces standard on outer seals. Tungsten Carbide vs. Carbon standard on inner seals.

All elastomers shall be nitrile.

For All Explosion Proof: Tungsten Carbide vs. Ceramic faces standard on outer and inner seals. All elastomers shall be viton.

Seal Sensor / High Temperature Probe: Located in motor housing. If pumpage should begin to leak past lower seal it indicates to pump control panel a fault has occurred.

Requires MiniCAS device in the control panel.

Capable of running dry without damage to components.

Designed for continuous operation, when fully submerged.

Explosion-proof available as option. FM approved.

Shaft: Corrosion resistant, 400 series stainless steel. Taper lock and impeller bolt on all models to guard against component damage on accidental reverse rotation.

Fasteners: 300 series stainless steel.

Grease for life bearings



3GV Plus

SUBMERSIBLE 3" SEWAGE PUMP - DUAL SEAL WITH SEAL SENSOR PROBE

APPLICATIONS

Specifically designed for the following uses:

- Sewage systems
- Dewatering/Effluent
- Water transfer
- Light industrial
- Commercial applications

Anywhere waste or drainage must be disposed of quickly, quietly and efficiently.

SPECIFICATIONS

Pump:

- Maximum soft solid size: 2½"
- Capacities: up to 575 GPM
- Total heads: up to 152' TDH
- Discharge size: 3" ANSI Flange

Motor:

- Maximum ambient temperature: 104° F (40° C) continuous duty
- Rated for continuous duty when fully submerged
- Insulation: Class H
- 60 Hertz
- Single row ball bearings
- 400 Series stainless steel taper lock shaft
- Requires overload protection in panel (not included)
- Includes high temperature sensor for winding protection

AIR-FILLED MOTOR

- Efficient heat dissipation
- Run dry capability
- Class H insulation
- Designed for Continuous Operation: Pump ratings are within the motor manufacturer's recommended working limits and can be operated continuously without damage when fully submerged.
- Bearings: Upper and lower heavy duty ball bearing construction for precision positioning of parts and to carry thrust loads.
- High temperature winding protection
- Cord: Severe duty rated, oil and water resistant. 30 foot standard.
- O-ring: Assures positive sealing against contaminants and oil leakage.

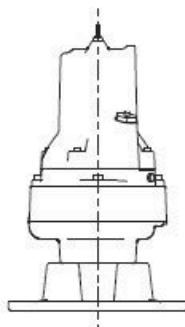

* Shown with support kit (sold separately).

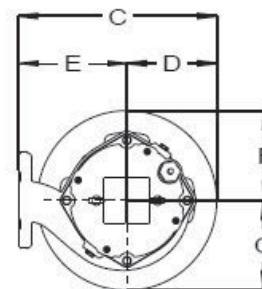
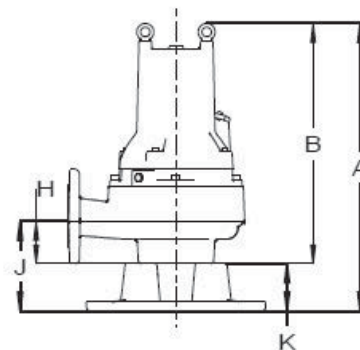

DIMENSIONS

Model No.	A	B	C	D	E	F	G	H	J	K
3GV A, B, C, D Impeller	27.95" [710]	24.02" [610]	15.75" [400]	7.48" [190]	8.27" [210]	7.48" [190]	7.48" [190]	3.94" [100]	7.87" [200]	3.94" [100]
3GV F, G, H Impeller	24.53" [623]	20.59" [523]	15.35" [390]	7.48" [190]	7.87" [200]	7.48" [190]	7.48" [190]	3.94" [100]	7.87" [200]	3.94" [100]

Stand Optional, Part no. 15K80

MODEL AND MOTOR INFORMATION

Model No.	HP	Volts	Phase/Hz	Rated Current (Amps)	RPM	Impeller Diameter In (mm)	Insulation Class	Run Capacitor (mfd/ volt)	Start Capacitor (mfd/ volt)	Resistance (Ohms)	Aux. Resistance (Ohms)	Start Current (LR Amps)	Rated Motor kVA [Code]	Rated Motor Eff. (%)	Rated Power Factor (cos phi)	Starting Torque (NM)	Max. Torque (NM)	Pump Weight (lbs.)	Cable Size with water detector and thermostats
3GV1112AD	11.0 (8.2 Kw)	200	3/60	30.0	3450	"A"	H	N/A	N/A	0.327	N/A	250	7.9 [J]	89.1	0.90	45.0	80.0	235	10AWG / 3-2-1-GC
3GV1113AD		230		26.0		5.71" (145 mm)				0.289		224	8.1 [K]	89.2	0.88	43.0	81.0		
3GV1114AD		460		13.0		1.156				112		89.1		0.86	49.0	88.0			
3GV1115AD		575		11.0		2.470				96		8.7 [K]		89.1	0.86	49.0	88.0		
3GV9512BD	9.5 (7.1 Kw)	200		26.5		"B"				0.327		250	7.9 [J]	89.1	0.90	45.0	80.0		
3GV9513BD		230		23.0		5.43" (138 mm)				0.289		224	8.1 [K]	89.2	0.88	43.0	81.0		
3GV9514BD		460		11.5		1.156				112		8.7 [K]		89.1	0.86	49.0	88.0		
3GV9515BD		575		9.7		2.470				96		8.7 [K]		89.1	0.86	49.0	88.0		
3GV8212CD	8.2 (6.1 Kw)	200		23.7		"C"				0.327		250	7.9 [J]	89.1	0.90	45.0	80.0		
3GV8213CD		230		20.6		5.12" (130 mm)				0.289		224	8.1 [K]	89.2	0.88	43.0	81.0		
3GV8214CD		460		10.3		1.156				112		8.7 [K]		89.1	0.86	49.0	88.0		
3GV8215CD		575		8.7		2.470				96		8.7 [K]		89.1	0.86	49.0	88.0		
3GV6512DD	6.5 (4.9 Kw)	200		20.7		"D"				0.327		250	7.9 [J]	89.1	0.90	45.0	80.0		
3GV6513DD		230		18.0		4.84" (123 mm)				0.289		224	8.1 [K]	89.2	0.88	43.0	81.0		
3GV6514DD		460		9.0		1.156				112		8.7 [K]		89.1	0.86	49.0	88.0		
3GV6515DD		575		7.6		2.470				96		8.7 [K]		89.1	0.86	49.0	88.0		
3GV6412FD	6.4 (4.8 Kw)	200	18.0	"F"	1.120	127	6.8 [H]	84.8	0.89	27.0	38.0								
3GV6413FD		230	16.0	4.65" (118 mm)	1.050	110	6.8 [H]	85.3	0.89	23.0	38.0								
3GV6414FD		460	8.0	4.200	54	6.7 [H]	84.9	0.89	25.0	38.0									
3GV6415FD		575	6.3	9.730	43	6.7 [H]	84.5	0.90	26.0	37.0									
3GV5512GD	5.5 (4.1 Kw)	200	15.3	"G"	1.120	127	6.8 [H]	84.8	0.89	27.0	38.0								
3GV5513GD		230	13.6	4.29" (109 mm)	1.050	110	6.8 [H]	85.3	0.89	23.0	38.0								
3GV5514GD		460	6.8	4.200	54	6.7 [H]	84.9	0.89	25.0	38.0									
3GV5515GD		575	5.4	9.730	43	6.7 [H]	84.5	0.90	26.0	37.0									
3GV4412HD	4.4 (3.3 Kw)	200	13.1	"H"	1.120	127	6.8 [H]	84.8	0.89	27.0	38.0								
3GV4413HD		230	11.6	3.98" (101 mm)	1.050	110	6.8 [H]	85.3	0.89	23.0	38.0								
3GV4414HD		460	5.8	4.200	54	6.7 [H]	84.9	0.89	25.0	38.0									
3GV4415HD		575	4.6	9.730	43	6.7 [H]	84.5	0.90	26.0	37.0									

APPLICATION DATA

Maximum Working Pressure	75 PSI (5 bar) - Standard
	150 PSI (10 bar) - Explosion Proof
Maximum Submergence	66 feet (20 m)
Minimum Submergence	Fully submerged for continuous operation
Maximum Environmental Temperature	40°C (104°F) continuous operation

CONSTRUCTION DETAILS

Power / Sensor Cable	10/3-2-1 GC, type: three phase - 6.5 HP and up
	10/3-2-1 GC, type: three phase - 6.5 HP and less
Motor Cover	Gray Cast Iron - ASTM A48 Class 30
Seal / Bearing Housing	Gray Cast Iron - ASTM A48 Class 30
Casing	Gray Cast Iron - ASTM A48 Class 30
Impeller	Cast Iron
Motor Shaft	AISI 400 Series Stainless Steel
Motor Design	Air filled Class H
Motor Overload Protection	Three Phase: require ambient compensated Class 10, quick trip overloads in the control panel.
Motor Seal Fail / High Temp. Detection	Seal fail sensor and high temp. in motor chamber. Connect to optional relays in control panel.
External Hardware	300 Series Stainless steel
Impeller Type	Vortex with pump out vanes on back shroud
Oil Capacity - Seal Chamber	33.8 ounces

MATERIALS OF CONSTRUCTION

Item No.	Part Name	Material			
		Standard			
1	Impeller	Cast Iron			
2	Motor Cover	Cast Iron			
3	Shaft	400 SS			
4	Fasteners	300 SS			
5	Ball Bearings	Steel			
6	Power Cable	SOW, 30 feet			
7	O-Ring	BUNA-N			
8	Service	Rotary	Stationary	Elastomers	Metal Parts
	Upper	Carbon / Ceramic		Nitrile	300 Series SS
	Outer	Tungsten Carbide / Ceramic			

NOMENCLATURE DESCRIPTION

1st Character - Discharge Size

3 = 3" discharge

2nd and 3rd Characters - Series/Solids Size

GV = Vortex

4th Character - HP

44 = 4.4 HP 82 = 8.2 HP
 55 = 5.5 HP 95 = 9.5 HP
 64 = 6.4 HP 11 = 11.0 HP
 65 = 6.5 HP

5th Character - Mechanical Seals

1 = 60 Hz/3500 RPM

6th Character - Phase/Voltage

2 = three phase, 200 V
 3 = three phase, 230 V
 4 = three phase, 460 V
 5 = three phase, 575 V

7th Character - Impeller Diameter

Vortex

A = 5.71" F = 4.65"
 B = 5.43" G = 4.29"
 C = 5.12" H = 3.98"
 D = 4.84"

8th Character - Cord Length

D = 30' (standard)
 J = 100' (optional)

9th Character

X = Explosion Proof



Xylem Inc.
 2881 East Bayard Street Ext., Suite A
 Seneca Falls, NY 13148
 Phone: (866) 325-4210
 Fax: (888) 322-5877
www.gouldswatertechnology.com

Goulds is a registered trademark of Goulds Pumps, Inc. and is used under license.
 © 2015 Xylem Inc. B3GVPLUS R3 August 2015