

**Dry Disconnects .....A-2 to A-12**

Bayloc™ style.....	A-2 to A-4
Coupler x female NPT.....	A-2
Greaseless coupler x female NPT .....	A-2
Coupler locking kit.....	A-2
Adapter x female NPT.....	A-3
Jump size adapter x female NPT.....	A-3
Adapter x 150# ASA flange.....	A-3
Vapor adapter x female NPSM .....	A-4
Cam & groove actuator style couplers.....	A-4
Bayonet style.....	A-5
90° swivel coupler x female NPT .....	A-5
Straight coupler x female NPT .....	A-5
Straight swivel coupler x female NPT .....	A-5
Dust plugs.....	A-5
Adapter x female NPT.....	A-5
Dust caps.....	A-5
Mann Tek style.....	A-6 to A-12
Coupler hose unit x female NPT .....	A-7
Coupler x 150# ASA flange.....	A-7
Coupler x TTMA flange .....	A-7
Dust plugs.....	A-7
Adapter tank unit x female NPT .....	A-8
Adapter tank unit x 150# flange .....	A-8
Adapter tank unit x TTMA flange.....	A-8
Dust caps.....	A-8
Steam coupler x female NPT .....	A-9
Steam adapter x female NPT.....	A-9
Dry gas couplings.....	A-10
Coupler hose unit x female NPT .....	A-10
Dust plugs.....	A-10
Adapter tank unit x female NPT .....	A-10
Adapter tank unit x female ACME .....	A-10
Adapter tank unit x 150# ASA flange .....	A-10
Dust caps.....	A-10
Dry aviation couplings .....	A-11 to A-12
Coupler x female NPT.....	A-11
Coupler x female BSP.....	A-11
Dust plug.....	A-11
Adapter x female NPT.....	A-12
Adapter x 150# ASA flange.....	A-12
Dust cap.....	A-12

**Safety Break-aways .....A-13 to A-14**

Marine series.....	A-13
Female NPT coupling .....	A-13
Male NPT coupling.....	A-13
150# flange .....	A-13
Industrial series .....	A-14
Female NPT coupling .....	A-14

**Safety Break-aways (cont.) ....A-13 to A-14**

Male NPT coupling.....	A-14
150# flange coupling.....	A-14
TTMA flanged.....	A-14

**FloMAX Refueling.....A-15 to A-23**

Diesel series.....	A-15 to A-17
Nozzles .....	A-15
Receiver, one-piece body .....	A-15
Receiver, two-piece body.....	A-15
Non-interchange nozzles and receivers.....	A-16
2" nozzles and receivers.....	A-16
Gravity fill receivers.....	A-17
Fuel vents .....	A-17
Fuel swivels .....	A-17
Service box .....	A-17
Standard series .....	A-18 to A-19
Engine oil nozzles and receivers .....	A-18
Coolant fluid nozzles and receivers .....	A-18
Hydraulic oil nozzles and receivers.....	A-19
Transmission nozzles and receivers.....	A-19
R series .....	A-20 to A-21
Engine oil nozzles and receivers .....	A-20
Coolant fluid nozzles and receivers .....	A-20
Hydraulic oil nozzles and receivers.....	A-21
Transmission fluid nozzles and receivers .....	A-21
High flow series .....	A-22
¾" nozzles .....	A-22
1" nozzles and receivers.....	A-22
Part number cross reference.....	A-23

**Tank Truck Fittings.....A-24 to A-42**

API.....	A-24 to A-27
API couplers .....	A-24
With bonded nose seal .....	A-24
With replaceable nose seal.....	A-24
Locking handle repair kit.....	A-24
API valves.....	A-24
Load only .....	A-24
Load / unload .....	A-24
API drop adapters.....	A-25
With sight glass.....	A-25
Gravity drop adapters .....	A-25
Repair kits.....	A-25
API Dust caps.....	A-25
Gravity drop adapter dust caps.....	A-26
Dixon Bayco adapters and couplers with grounding tab .....	A-26
API compatible rack cords.....	A-27
Optic assemblies.....	A-26
Thermistor assemblies.....	A-27
Replacement parts.....	A-27



## Tank Truck Fittings (cont.) ..... A-24 to A-42

Dixon® vapor recovery couplers .....	A-28 to A-29
With probe x adapter .....	A-28
With probe x coupler with probe .....	A-28
Coupler x hose shank .....	A-28
Coupler x 45° hose shank .....	A-29
With probe coupler x female NPT .....	A-29
TTMA .....	A-30 to A-33
Flanged tee .....	A-30
Flanged adapters .....	A-30
Flange x male NPT .....	A-30
Flange x extended length male NPT .....	A-30
Flange x female NPT .....	A-30
Slip-on socket weld flange .....	A-30
Buttweld flange .....	A-30
Flange extension with port .....	A-31
Flange extensions .....	A-31
Cam and groove .....	A-31
Adapter x TTMA flange .....	A-31
Coupler x TTMA flange .....	A-31
22½° adapter x TTMA flange .....	A-31
22½° coupler x TTMA flange .....	A-31
Flange gaskets .....	A-32
Sight Flow Indicators .....	A-32 to A-33
TTMA flanged short sight flow indicators .....	A-32
TTMA flanged sight flow indicators .....	A-32 to A-33
Repair kits .....	A-33
Flange screen .....	A-33
Tank Transport Equipment .....	A-34 to A-35
Fusible pipe caps .....	A-34
Pipe caps .....	A-34
Reducers .....	A-34
Reducing cap .....	A-34
Coupling gaskets .....	A-34
Pipe caps .....	A-35
Thread adapters .....	A-35
Cam and groove adapter .....	A-35
6200 series side lever type drop elbows .....	A-36
6500 series self-locking drop elbows .....	A-36
Inlets .....	A-36
Male adapter .....	A-36
Female coupler .....	A-36
Female NPT .....	A-36
Dual point vapor recovery elbows, ball lever .....	A-37
Adapter inlet .....	A-37
Single point coaxial drop elbow .....	A-37
Adapter fuel inlets .....	A-37
Coupler fuel inlets .....	A-37

## Tank Truck Fittings (cont.) ..... A-24 to A-42

Tight fill .....	A-38
Elbows, complete unit .....	A-38
Elbow coupler body .....	A-38
Male adapter inlet end .....	A-38
Side seal .....	A-38
Drop elbow .....	A-38
Side seal to top seal adapter .....	A-38
Dust caps and plugs with pull handle .....	A-39
Reelcraft® static discharge reel .....	A-39
TFA series fill pipe adapter .....	A-40
Fuel delivery tank adapters .....	A-40
Vapor recovery tank adapters .....	A-40
Caps .....	A-41 to A-42
Vapor caps .....	A-41
Automatic pressure / vacuum relief caps .....	A-41
Standard stationary vent caps .....	A-42
Fuel delivery adapter cap .....	A-42

## Swivels ..... A-43 to A-47

Swivel joints .....	A-43
Single plane style .....	A-44
Double plane style .....	A-44, A-45
Triple plane style .....	A-45
Ordering Information .....	A-46
Loading arm .....	A-47
Split flange .....	A-47

## Railroad tank car connections ... A-48 to A-51

Style A .....	A-48
Style F .....	A-48
Style GF .....	A-48
Style S .....	A-48
Style T .....	A-49
Dixon® coupler x tank car thread .....	A-49
EZ Boss-Lock™ x coupler tank car thread .....	A-49
Railroad unloading assemblies .....	A-50
Dixon® tank car adapters .....	A-50
Cam and groove railroad tank car gaskets .....	A-51
Pin lug wrench .....	A-51

## Threaded Pipe Fittings ..... A-52

Sight flow indicators .....	A-52
-----------------------------	------

Bayloc™ Dry Disconnect Coupler x Female NPT

Features:

- automatic closing poppet assembly
- must be used with a DBA style adapter for coupler to operate, sold separately
- fully interchangeable with Kamvalok (OPW trademark) fittings
- maximum operating pressure at 70°F (21°C):
  - 1½" - 210 PSI
  - 2" - 150 PSI
  - 3" - 120 PSI
- aluminum fittings have stainless internals equivalent to 304 stainless



- stainless handle allows exposure to corrosive chemicals or wash down service
- heavy duty handle attachment prevents bending of crank assembly
- one piece stainless crank and link provide long service life
- EZ Boss-Lock™ cam arms, standard on all 1½" and 2" fittings, provide high security from accidental opening due to vibration or snagging
- large paddle type locking cam arms, standard on 3" fittings, allow for an easy grip



coupler x 1½" or 2" female NPT



coupler x 3" female NPT

Female NPT	Coupler Size	Seal Material	Maximum PSI at 70°F (21°C)	Aluminum		Stainless Steel <sup>1</sup>	
				Part #	Price/E	Part #	Price/E
1½"	2"	Buna	210	DBC61-150	\$753.40	DBC71-150	\$1668.00
	2"		150	DBC61-200	792.55	DBC71-200	1855.75
	3"		120	DBC61-300	1650.70	DBC71-300	3983.20
2"	2½"	FKM	210	DBC62-150	816.85	DBC72-150	1731.90
	2"		150	DBC62-200	887.90	DBC72-200	1951.65
	3"		120	DBC62-300	1842.45	DBC72-300	4194.95
3"	2"	PTFE Encapsulated Silicone & FFPM	210	DBC63-150	1853.75	DBC73-150	2427.10
	2"		150	DBC63-200	2124.15	DBC73-200	2838.60
	3"		120	DBC63-300	3413.85	DBC73-300	5627.20
1½"	2"	EPDM	210	DBC64-150	1174.65	DBC74-150	1731.90
	2"		150	DBC64-200	1303.75	DBC74-200	1951.65
	3"		120	DBC64-300	2115.95	DBC74-300	4194.95
2"	2"	FFPM and PTFE <sup>2</sup>	210	---	---	DBC76-150	5193.75
	2"		150	DBC66-200	4888.10	DBC76-200	5633.25
	3"		120	DBC66-300	8060.25	DBC76-300	11649.90
1½"	2"	PTFE Encapsulated FKM & FFPM	210	---	---	DBC77-150	2486.25
	2"		150	---	---	DBC77-200	2455.65
	3"		120	---	---	DBC77-300	5215.75
3"	4"	FKM-B	120	DBC69-300	2223.30	DBC79-300	4592.50

Bayloc™ Dry Disconnect Greaseless Coupler x Female NPT



Female NPT	Coupler Size	Seal Material	Stainless Steel <sup>1</sup>	
			Part #	Price/E
1½"	2"	PTFE Encapsulated	DBC77-150-GL	\$2764.70
2"	2½"	FKM & FFPM	DBC77-200-GL	2950.45

<sup>1</sup> stainless steel corrosion resistance is equivalent to 304 stainless steel

<sup>2</sup> FFPM gasket, main seal O-ring and handle O-ring, PTFE seals on cylinder assembly, stuffing box, and seal under poppet screw

Bayloc™ Dry Disconnect Coupler x 90° Swivel Female NPT



Female NPT	Coupler Size	Seal Material	Aluminum	
			Part #	Price/E
2"	2½"	Buna	DBS61-200	\$960.85
2"	2½"	FKM	DBS62-200	1108.30
2"	2½"	PTFE Encapsulated Silicone & FFPM	DBS63-200	2251.45

Bayloc™ Dry Disconnect Coupler Locking Kit



Description	Aluminum	
	Part #	Price/E
for use with 1½" and 2" dry disconnect couplers	DBCL-200	\$106.70
for use with 3" dry disconnect couplers	DBCL-300	106.70

Note: Reference page D-59 for dust plugs for couplers.

Bayloc™ Dry Disconnect Adapter x Female NPT

**Applications:**

- compatible with most cam and groove style dry disconnects
- helps prevent spillage from normal or accidental disconnects
- spring loaded sealing device snaps closed should valve become disconnected with the poppet open

**Features:**

- two-piece adapter design for easy rebuilding of adapters
- fully interchangeable with Kamvalok (OPW trademark) style fittings
- for pressure ratings at other temperatures, contact Dixon®
- contact Dixon® at 800.355.1991 for chemical compatibility, size, material selection and special configurations

Female NPT	Adapter Size	Seal Material	Maximum PSI at 70°F (21°C)	Aluminum		Stainless Steel		
				Part #	Price/E	Part #	Price/E	
1½"	2"	Buna	210	DBA11-150	\$205.70	DBA71-150	\$500.90	
	2"		2½"	150	DBA11-200	222.95	DBA71-200	573.85
	3"		4"	120	DBA11-300	435.55	DBA71-300	1284.45
1½"	2"	FKM	210	DBA12-150	210.10	DBA72-150	500.90	
	2"		2½"	150	DBA12-200	229.40	DBA72-200	643.75
	3"		4"	120	DBA12-300	449.45	DBA72-300	1302.45
1½"	2"	PTFE Encapsulated Silicone	210	DBA63-150	276.85	DBA73-150	506.35	
	2"		2½"	150	DBA63-200	319.60	DBA73-200	648.15
	3"		4"	120	DBA63-300	479.45	DBA73-300	1510.20
1½"	2"	EPDM	210	DBA64-150	255.70	DBA74-150	519.40	
	2"		2½"	150	DBA64-200	291.70	DBA74-200	573.85
	3"		4"	120	DBA64-300	559.30	DBA74-300	1416.25
1½"	2"	FFPM	210	DBA66-150	878.90	DBA76-150	1174.60	
	2"		2½"	150	DBA66-200	1084.05	DBA76-200	1298.45
	3"		4"	120	DBA66-300	1877.70	DBA76-300	2876.40
1½"	2"	PTFE Encapsulated FKM	210	---	---	DBA77-150	557.35	
	2"		2½"	150	---	---	DBA77-200	679.20
	3"		4"	120	---	---	DBA77-300	1376.35
3"	4"	FKM-B	120	DBA69-300	687.20	---	---	



adapter x 1½" and 2" female NPT



adapter x 3" female NPT

Bayloc™ Dry Disconnect Jump Size Adapter x Female NPT

Female NPT	Adapter Size	Seal Material	Maximum PSI at 70°F (21°C)	Aluminum	
				Part #	Price/E
2"	2"	Buna	150	DBA11-1520	\$214.75
2"	2"	FKM	150	DBA12-1520	224.15



Bayloc™ Dry Disconnect Adapter x 150# ASA Flange

Female NPT	Adapter Size	Seal Material	Maximum PSI at 70°F (21°C)	Stainless Steel	
				Part #	Price/E
2"	2"	FKM	150	DBAF72-1520	\$1172.35
		PTFE Encapsulated Silicone		DBAF73-1520	1184.00
		EPDM		DBAF74-1520	1184.00
		FFPM		DBAF76-1520	1717.55
		FKM		DBAF72-200	1210.85
2"	2½"	PTFE Encapsulated Silicone	150	DBAF73-200	1221.10
		EPDM		DBAF74-200	1221.10
		FFPM		DBAF76-200	1928.50
		FKM		DBAF72-300	1928.60
		PTFE Encapsulated Silicone		DBAF73-300	2010.15
3"	4"	EPDM	150	DBAF74-300	2010.15
		FFPM		DBAF76-300	3175.10



Note: Reference page D-59 for dust caps for adapters

- For flange dimensions, diagrams and additional information please reference dixonvalve.com.

## Bayloc™ Dry Disconnect Vapor Adapter x Female NPSM



Female NPSM	Adapter Size	Seal	Max PSI at 70°F (21°C)	Stainless Steel <sup>1</sup>	
				Part #	Price/E
1½"	2"	PTFE	150	DBAV73-2030	\$685.45

<sup>1</sup> stainless steel corrosion resistance is equivalent to 304 stainless steel

Note: Reference page D-59 for dust caps for adapters

## Cam &amp; Groove Actuator Style Couplers

**Applications:**

- suited for vapor recovery, suction pump line and other applications where it is necessary to easily drain the hose or pipe for cleaning
- can also be used when product retention in a hose or pipe is desired and damage from accidental spill from an open coupler is not a concern
- couplers work with the DBA popped adapters on page A-3 in applications where automatic closure for the coupler is not desired

**Features:**

- EZ Boss-Lock™ cam arms
- stainless steel locking lever standard
- use with standard cam and groove dust plugs sized one size larger than the dry disconnect size
- prevents spillage from normal and accidental disconnection of the connection

**Materials:**

- 316 stainless steel body
- 304 stainless steel internal components
- replacement parts are available, contact Dixon® for more information



Female NPT	Coupler Size	Seal Material	Stainless Steel	
			Part #	Price/E
1½"	2"	Buna	D2C71-150	\$1030.85
2"	2½"		D2C71-200	1135.10
1½"	2"	FKM	D2C72-150	1051.40
2"	2½"		D2C72-200	1156.90
1½"	2"	PTFE Encapsulated Silicone	D2C73-150	1272.75
2"	2½"		D2C73-200	1347.35
1½"	2"	EPDM	D2C74-150	1030.85
2"	2½"		D2C74-200	1135.10
1½"	2"	PTFE Encapsulated FKM	D2C77-150	1272.75
2"	2½"		D2C77-200	1347.35
1½"	2"	FKM-B	D2C79-150	1102.90
2"	2½"		D2C79-200	1214.60



**Application:**

- for the spill-less transfer of petroleum products such as fuel oil, lube oil blending and tank truck delivery

**Feature:**

- ensures a spill free connection, fluid cannot flow until couplings are connected together and valve is opened; coupling can then not be disconnected until the valve handle is closed
- maximum operating pressure: **85 PSI @ 70°F (21°C)**, for pressure ratings at other temperatures contact Dixon®
- replacement parts available, contact Dixon® for more information

**Bayonet Style Dry Disconnect 90° Swivel Coupler x Female NPT**

Size	Seal Material	Anodized Aluminum	
		Part #	Price/E
2"	Buna	<b>BS61-200</b>	<b>\$864.95</b>
2"	FKM	<b>BS62-200</b>	<b>932.90</b>
3"	Buna	<b>BS61-300</b>	<b>1478.20</b>
3"	FKM	<b>BS62-300</b>	<b>1596.10</b>



**Bayonet Style Dry Disconnect Straight Coupler x Female NPT**

Size	Seal Material	Anodized Aluminum	
		Part #	Price/E
2"	Buna	<b>BC61-200</b>	<b>\$687.20</b>
2"	FKM	<b>BC62-200</b>	<b>749.15</b>



**Bayonet Style Dry Disconnect Straight Swivel Coupler x Female NPT**

Size	Seal Material	Anodized Aluminum	
		Part #	Price/E
2"	Buna	<b>BSS61-200</b>	<b>\$864.95</b>
2"	FKM	<b>BSS62-200</b>	<b>932.90</b>
3"	Buna	<b>BSS61-300</b>	<b>1396.35</b>
3"	FKM	<b>BSS62-300</b>	<b>1516.20</b>



**Bayonet Style Dust Plugs**

Size	Rubber with Stainless Steel Chain	
	Part #	Price/E
2"	<b>BCP-200</b>	<b>\$64.55</b>
3"	<b>BCP-300</b>	<b>73.45</b>



**Bayonet Style Dry Disconnect Adapter x Female NPT**

Size	Seal Material	Stainless Steel		Brass		Aluminum	
		Part #	Price/E	Part #	Price/E	Part #	Price/E
2"	Buna	<b>BA31-200</b>	<b>\$215.75</b>	---	---	---	---
2"	FKM	<b>BA32-200</b>	<b>215.75</b>	---	---	---	---
3"	Buna	---	---	<b>BA31-300</b>	<b>\$523.35</b>	<b>BA61-300</b>	<b>\$479.45</b>
3"	FKM	---	---	<b>BA32-300</b>	<b>523.35</b>	<b>BA62-300</b>	<b>479.45</b>



**Bayonet Style Dust Caps**

Size	Rubber with Stainless Steel Chain	
	Part #	Price/E
2"	<b>BAC-200</b>	<b>\$50.95</b>
3"	<b>BAC-300</b>	<b>56.65</b>



## Mann Tek Dry Disconnect Couplings

### Applications:

- used by producers of ink, adhesives, fatty acids, pharmaceuticals, liquid soaps, petroleum, chemicals, agricultural and a wide variety of common caustic and specialty acids
- designed for the quick and spill free connection and disconnection of hoses and pipelines

### Features:

- easy to handle - push and turn - free flow, turn and pull - closed
- time saving - no need to drain hoses or pipe systems
- economical - no loss or spillage of liquids at connection or disconnection
- safety - the valve cannot be opened until the unit is coupled
- environmental friendly - accidental spillage eliminated when proper used
- safe and reliable - due to rugged construction
- product life - uncomplicated design and high quality materials ensures long product life
- selectivity - To avoid product contamination, selective versions of the couplers and adapters are available. Contact Dixon® for further information.
- produced according to NATO standard STANAG 3756 and ATOFINA SGM 2049.TUY.C.
- working pressure at ambient temperature **70°F (21°C)**:
  - aluminum: **230 PSI**, up to 4"
  - brass/ gunmetal <sup>1</sup>: **230 PSI**, up to 4"
  - stainless steel: **360 PSI**
- standard seal supplied: FKM
- optional seals:
  - EPDM
  - NBR - nitrile
  - Kalrez®
  - Chemraz®
- seal kits are available
- interchanges with Avery Hardoll and Todo-matic®

<sup>1</sup> produced to US government bronze specification G



## How it Works

The principle of operation is identical for all sizes of couplings.

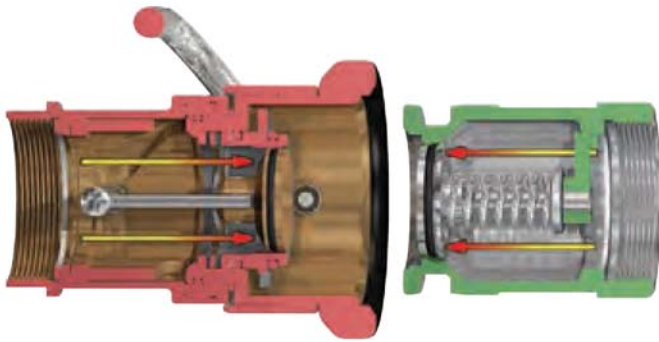

Closed:

- Turn and pull  
it's released - no spillage

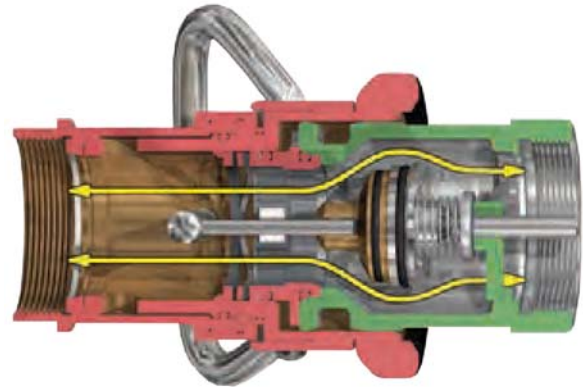

Open:

- Push and turn  
it's coupled - full flow

## Mann Tek Dry Disconnect Couplers - Hose Unit

**Features:**

- coupler has built-in swivel
- stainless steel ball bearings
- stainless steel shaft journal embedded in PTFE to eliminate seizure
- riveted piston pin to minimize the risk for failure under extreme pressure conditions
- the protective ring is a specially formulated, weather resistant and electrically conductive rubber compound
- all wetted parts are stainless steel
- stainless steel couplers: rollers are Hastelloy C276 on the stainless steel shaft
- aluminum and brass couplers: rollers are aluminum-bronze on the stainless steel shaft
- composite (Polyeten PE-HD 300) plugs provide good protection against corrosion and withstand hot and cold environments

### Coupler - Hose Unit x Female NPT



Female NPT	Body Size	316 Stainless Steel		Aluminum		Brass / Gunmetal <sup>1</sup>	
		Part #	Price/E	Part #	Price/E	Part #	Price/E
3/4"	56 mm	<b>DDC075SS</b>	<b>\$1764.45</b>	<b>DDC075AL</b>	<b>\$934.65</b>	<b>DDC075BR</b>	<b>\$1311.40</b>
1"	56 mm	<b>DDC100SS</b>	<b>1764.45</b>	<b>DDC100AL</b>	<b>934.65</b>	<b>DDC100BR</b>	<b>1311.40</b>
1 1/2"	70 mm	<b>DDC150SS</b>	<b>2710.30</b>	<b>DDC150AL</b>	<b>1355.15</b>	<b>DDC150BR</b>	<b>1627.95</b>
2"	70 mm	<b>DDC200SS</b>	<b>2775.55</b>	<b>DDC200AL</b>	<b>1355.15</b>	<b>DDC200BR</b>	<b>1627.95</b>
3"	105 mm	<b>DDC300SS105</b>	<b>4698.55</b>	<b>DDC300AL105</b>	<b>1518.95</b>	<b>DDC300GM105</b>	<b>2154.50</b>
3"	119 mm	<b>DDC300SS</b>	<b>4721.95</b>	<b>DDC300AL</b>	<b>1552.40</b>	<b>DDC300GM</b>	<b>2404.90</b>
4"	164 mm	<b>DDC400SS</b>	<b>8137.20</b>	<b>DDC400AL</b>	<b>3220.15</b>	<b>DDC400GM</b>	<b>4372.35</b>
6"	238 mm	<b>DDC600SS</b>	<b>22275.20</b>	<b>DDC600AL</b>	<b>11312.40</b>	---	---

<sup>1</sup> produced to US government bronze specification G

### Coupler - Hose Unit x 150# ASA Flange

150# Flange	Body Size	316 Stainless Steel	
		Part #	Price/E
2"	70 mm	<b>DDC200SSFL</b>	<b>\$4237.50</b>
3"	119 mm	<b>DDC300SSFL</b>	<b>6569.60</b>
4"	164 mm	<b>DDC400SSFL</b>	<b>10351.30</b>
6"	238 mm	<b>DDC600SSFL</b>	<b>21214.50</b>
8"	272 mm	<b>DDC800SSFL</b>	<b>78697.45</b>



- For flange dimensions, diagrams and additional information please reference [dixonvalve.com](http://dixonvalve.com).

### Coupler - Hose Unit x TTMA Flange

TTMA Flange	Body Size	Aluminum	
		Part #	Price/E
4"	164 mm	<b>DDC400AL164TTMA</b>	<b>\$4324.30</b>



- For flange dimensions, diagrams and additional information please reference [dixonvalve.com](http://dixonvalve.com).

### Dust Plugs for Coupler - Hose Unit

Size	Body Size	Polyeten PE-HD 300	
		Part #	Price/E
3/4" and 1"	56 mm	<b>DDDP075</b>	<b>\$87.90</b>
1 1/2" and 2"	70 mm	<b>DDDP150</b>	<b>91.15</b>
3"	105 mm	<b>DDDP300105</b>	<b>94.10</b>
3"	119 mm	<b>DDDP300</b>	<b>94.10</b>
4"	164 mm	<b>DDDP400</b>	<b>188.45</b>
6"	238 mm	<b>DDDP600<sup>1</sup></b>	<b>504.20</b>



<sup>1</sup> 6" is aluminum



## Mann Tek Dry Disconnect Adapters - Tank Unit

**Application:**

- usually installed on the tank or manifold

**Features:**

- conical valve seat reduces the risk for piston blow out
- PTFE bearing between piston shaft and guide eliminates risk of seizure
- aluminum adapter: aluminum poppet, stainless steel internal parts
- stainless steel adapter: stainless steel poppet, stainless steel internal parts
- brass / gunmetal <sup>1</sup> adapter: brass poppet, brass and stainless steel internal parts
- composite (Polyeten PE-HD 300) cap to provide good protection in harsh environments
- FKM (FPM) gaskets standard on polyeten caps

## Adapter-Tank Unit x Female NPT



Female NPT	Body Size	316 Stainless Steel		Aluminum		Brass / Gunmetal <sup>1</sup>	
		Part #	Price/E	Part #	Price/E	Part #	Price/E
¾"	56 mm	<b>DDA075SS</b>	<b>\$642.35</b>	<b>DDA075AL</b>	<b>\$469.65</b>	<b>DDA075BR</b>	<b>\$534.25</b>
1"	56 mm	<b>DDA100SS</b>	<b>642.35</b>	<b>DDA100AL</b>	<b>469.65</b>	<b>DDA100BR</b>	<b>534.25</b>
1½"	70 mm	<b>DDA150SS</b>	<b>950.25</b>	<b>DDA150AL</b>	<b>472.25</b>	<b>DDA150BR</b>	<b>544.30</b>
2"	70 mm	<b>DDA200SS</b>	<b>950.25</b>	<b>DDA200AL</b>	<b>472.25</b>	<b>DDA200BR</b>	<b>544.30</b>
3"	105 mm	<b>DDA300SS105</b>	<b>1314.55</b>	<b>DDA300AL105</b>	<b>562.90</b>	<b>DDA300GM105</b>	<b>733.45</b>
3"	119 mm	<b>DDA300SS</b>	<b>1283.70</b>	<b>DDA300AL</b>	<b>580.60</b>	<b>DDA300GM</b>	<b>764.40</b>
4"	164 mm	<b>DDA400SS</b>	<b>2359.85</b>	<b>DDA400AL</b>	<b>1042.85</b>	<b>DDA400GM</b>	<b>1587.70</b>
6"	238 mm	<b>DDA600SS</b>	<b>8745.50</b>	<b>DDA600AL</b>	<b>4332.95</b>	---	---

## Adapter-Tank Unit x 150# ASA Flange



150# Flange	Body Size	316 Stainless Steel		Aluminum		Brass / Gunmetal <sup>1</sup>	
		Part #	Price/E	Part #	Price/E	Part #	Price/E
¾"	56 mm	<b>DDA075SSFL</b>	<b>\$1195.45</b>	---	---	---	---
1"	56 mm	<b>DDA100SSFL</b>	<b>1195.45</b>	<b>DDA100ALFL</b>	<b>\$836.25</b>	<b>DDA100BRFL</b>	<b>\$949.00</b>
1½"	70 mm	<b>DDA150SSFL</b>	<b>1257.25</b>	<b>DDA150ALFL</b>	<b>694.10</b>	<b>DDA150BRFL</b>	<b>957.55</b>
2"	70 mm	<b>DDA200SSFL</b>	<b>1257.25</b>	<b>DDA200ALFL</b>	<b>694.10</b>	<b>DDA200BRFL</b>	<b>957.55</b>
3"	105 mm	<b>DDA300SS105FL</b>	<b>1422.05</b>	<b>DDA300AL105FL</b>	<b>792.15</b>	<b>DDA300GM105FL</b>	<b>1051.25</b>
3"	119 mm	<b>DDA300SSFL</b>	<b>1754.80</b>	<b>DDA300ALFL</b>	<b>873.35</b>	<b>DDA300GMFL</b>	<b>1126.50</b>
4"	164 mm	<b>DDA400SSFL</b>	<b>2860.70</b>	<b>DDA400ALFL</b>	<b>1228.60</b>	<b>DDA400GMFL</b>	<b>2000.55</b>
6"	238 mm	<b>DDA600SSFL</b>	<b>9244.10</b>	<b>DDA600ALFL</b>	<b>4761.30</b>	---	---
8"	272 mm	<b>DDA800SSFL</b>	<b>33726.90</b>	---	---	---	---

<sup>1</sup> produced to US government bronze specification G

- For flange dimensions, diagrams and additional information please reference dixonvalve.com.

## Adapter-Tank Unit x TTMA Flange



TTMA Flange	Body Size	Aluminum	
		Part #	Price/E
3"	105 mm	<b>DDA300AL105TTMA</b>	<b>\$792.15</b>
3"	119 mm	<b>DDA300AL119TTMA</b>	<b>873.35</b>
4"	164 mm	<b>DDA400AL164TTMA</b>	<b>1228.60</b>

- For flange dimensions, diagrams and additional information please reference dixonvalve.com.

## Dust Caps for Adapter-Tank Unit



Size	Body Size	Polyeten PE-HD 300	
		Part #	Price/E
¾" and 1"	56 mm	<b>DDDC075</b>	<b>\$142.55</b>
1½" and 2"	70 mm	<b>DDDC150</b>	<b>156.10</b>
3"	105 mm	<b>DDDC300105</b>	<b>172.30</b>
3"	119 mm	<b>DDDC300</b>	<b>191.65</b>
4"	164 mm	<b>DDDC400</b>	<b>360.35</b>
6"	238 mm	<b>DDDC600</b> <sup>1</sup>	<b>1338.05</b>

<sup>1</sup> 6" dust cap is aluminum

Note: Reference page A-10 for rubber dust caps.



## Mann Tek Dry Disconnects for Steam Service

**Applications:**

- designed to fit hoses carrying steam used in chemical (heating), pharmaceutical (disinfection and sterilization) and at loading bays

**Features:**

- coupling housing and all inner parts: stainless steel
- EPDM 291 seal
- unintentional separation is eliminated preventing accidents and avoiding unintended down time
- performance unaffected by surface rust
- lockable versions are available on 1½" and 2", contact Dixon®
- couplers supplied with double handles
- **150 PSI at 350°F (177°C)**

### Coupler - Hose Unit x Female NPT

Female NPT	Body Size	316 Stainless Steel	
		Part #	Price/E
¾"	56 mm	<b>DDSC075SS</b>	<b>\$2423.05</b>
1"	56 mm	<b>DDSC100SS</b>	<b>2423.05</b>
1½"	70 mm	<b>DDSC150SS</b>	<b>2833.35</b>
2"	70 mm	<b>DDSC200SS</b>	<b>2833.35</b>



### Adapter - Tank Unit x Female NPT

Female NPT	Body Size	316 Stainless Steel	
		Part #	Price/E
¾"	56 mm	<b>DDSA075SS</b>	<b>\$745.50</b>
1"	56 mm	<b>DDSA100SS</b>	<b>745.50</b>
1½"	70 mm	<b>DDSA150SS</b>	<b>982.20</b>
2"	70 mm	<b>DDSA200SS</b>	<b>982.20</b>





## Mann Tek Dry Gas Couplings

### Applications:

- primary application is in the handling of LPG - Propane and Butane
- designed for loading and discharge of bobtails or intermediate bulk delivery trucks to and from rail cars

### Features:

- reliable, easy to maintain
- can be coupled to a tank unit with pressures up to **225 PSI** at ambient temperature **70°F (21°C)**, if pressure is higher, equip couplings with pressure relief valves.
- minimizes the risk of cold burns, spillage, product loss and health risks and keeps the environment free of hazardous vapors and liquids
- compatible with existing dry disconnect couplings
- stainless steel and brass / gunmetal (*produced to US government bronze specification G*)
- FKM (FPM) seals
- working pressure: **360 PSI** at ambient temperature **70°F (21°C)**
- composite (Polyeten PE-HD 300) plug provides good protection in harsh environments
- for pressure relief options contact Dixon®

### Coupler-Hose Unit x Female NPT



Female NPT	Body Size	316 Stainless Steel	
		Part #	Price/E
1"	56 mm	<b>DGC100SS</b>	<b>\$2238.20</b>
2"	71 mm	<b>DGC200SS</b>	<b>3370.90</b>
3"	119 mm	<b>DGC300SS</b>	<b>4751.90</b>

### Dust Plug for Dry Gas Adapter



Size	Body Size	Polyeten PE-HD 300	
		Part #	Price/E
1"	56 mm	<b>DGDP100</b>	<b>\$91.35</b>
2"	71 mm	<b>DGDP200</b>	<b>91.35</b>
3"	119 mm	<b>DGDP300</b>	<b>91.35</b>

### Adapter-Tank Unit x Female NPT



Female NPT	Body Size	316 Stainless Steel	
		Part #	Price/E
1"	56 mm	<b>DGA100SS</b>	<b>\$803.90</b>
2"	71 mm	<b>DGA200SS</b>	<b>1045.95</b>
3"	119 mm	<b>DGA300SS</b>	<b>1193.00</b>

### Adapter-Tank Unit x Female ACME



Female ACME	Body Size	316 Stainless Steel	
		Part #	Price/E
1¾"	56 mm	<b>DGA100SS175</b>	<b>\$2305.45</b>
3¼"	71 mm	<b>DGA200SS325</b>	<b>1806.00</b>

### Adapter-Tank Unit x 150# ASA Flange



150# Flange	Body Size	316 Stainless Steel	
		Part #	Price/E
1"	56 mm	<b>DGA100SSFL</b>	<b>\$1316.45</b>
2"	71 mm	<b>DGA200SSFL</b>	<b>1401.35</b>
3"	119 mm	<b>DGA300SSFL</b>	<b>1664.30</b>

- For flange dimensions, diagrams and additional information please reference [dixonvalve.com](http://dixonvalve.com).

### Dust Cap for Dry Gas Coupler



Size	Body Size	Material	Part #	Price/E
1"	56 mm	<i>polyeten PE-HD300</i>	<b>DGDC100</b>	<b>\$147.50</b>
2"	71 mm	<i>rubber</i>	<b>DGDC200</b>	<b>81.80</b>
3"	119 mm	<i>rubber</i>	<b>DGDC300</b>	<b>94.15</b>



## Mann Tek Dry Aviation Couplers - Hose Unit

**Application:**

- designed for use in aviation refueling systems

**Features:**

- working pressure: **150 PSI** at ambient temperature **70°F (21°C)**
- composite (Polyeten PE-HD 300) plug provides good protection in harsh environments
- accepts international standard 2½" point bayonet, hose end refueling nozzles according to: ISO45 / MS24484 / STANAG 3105 / British Aerospace Spec. 2C14, **they are not configured for under-wing refueling** 
- gunmetal coupling ring minimizes the risk of seizure
- riveted piston pin minimizes risk of failure under extreme pressure conditions
- protective ring is a specially formulated, weather resistant and electrically conductive rubber compound

**Materials:**

- body: high strength aluminum
- coupling ring: gunmetal (*produced to U.S. government bronze specification G*)
- bayonet flange and inner parts: stainless steel, aluminum
- all wetted parts are aluminum and stainless steel
- stainless steel ball bearings
- stainless steel shaft journal embedded in PTFE eliminates seizure
- PTFE bearings between the driving plate and piston guide eliminate the risk of seizure

### Coupler-Hose Unit x Female NPT

Female NPT	Body Size	Aluminum	
		Part #	Price/E
2½"	ISO 45	<b>DAC250AL</b>	<b>\$1786.30</b>
3"	ISO 45	<b>DAC300AL</b>	<b>1786.30</b>



### Coupler-Hose Unit x Female BSP

Female BSP	Body Size	Aluminum	
		Part #	Price/E
2½"	ISO 45	<b>DAC250ALBSP</b>	<b>\$1786.30</b>
3"	ISO 45	<b>DAC300ALBSP</b>	<b>1786.30</b>

### Dust Plug for Dry Aviation Coupler

Size	Body Size	Aluminum	
		Part #	Price/E
2½"	ISO 45	<b>DADP250</b>	<b>\$220.45</b>





## Mann Tek Dry Aviation Adapters - Tank Unit

**Application:**

- designed for use in aviation refueling systems

**Features:**

- working pressure: **150 PSI** at ambient temperature **70°F (21°C)**
- composite (Polyeten PE-HD 300) cap provides good protection in harsh environments
- accepts international standard 2½" point bayonet hose end refueling nozzles according to: ISO45 / MS24484 / STANAG 3105 / British Aerospace Spec. 2C14, **not configured for under-wing refueling** 
- gunmetal coupling ring minimizes the risk of seizure
- PTFE bearings between the piston shaft and the piston guide eliminate the risk of seizure
- conical valve seat eliminates the risk of piston blow out when extreme pressure is used

**Materials:**

- body: high strength aluminum
- coupling ring: gunmetal
- bayonet flange and inner parts: stainless steel, aluminum
- all wetted parts are in aluminum and stainless steel

## Adapter-Tank Unit x Female NPT



Size	Body Size	Aluminum	
		Part #	Price/E
2½"	ISO 45	<b>DAA250AL</b>	<b>\$1027.65</b>
3"	ISO 45	<b>DAA300AL</b>	<b>1027.65</b>

## Adapter-Tank Unit x 150# ASA Flange



150# Flange	Body Size	Aluminum	
		Part #	Price/E
2½"	ISO 45	<b>DAA250ALFL</b>	<b>\$1191.00</b>
3"	ISO 45	<b>DAA300ALFL</b>	<b>1189.85</b>

- For flange dimensions, diagrams and additional information please reference [dixonvalve.com](http://dixonvalve.com).

## Dust Cap for Dry Aviation Adapter



Size	Body Size	Polyeten PE-HD 300	
		Part #	Price/E
2½"	ISO 45	<b>DADC250</b>	<b>\$151.10</b>

## Mann Tek Safety Break-away Coupling - Marine Version

**Application:**

- typically for ship-to-offshore platform and ship-to-ship product transfer operations

**Features:**

- **designed to be installed within a hose string where the coupling will have a length of hose attached to both sides**
- minimizes spillage and damage associated with pull-away incidents
- coupling automatically senses excessive load, closes the valves and disconnects, release is executed when force causes bolts to break
- working pressure: **360 PSI** at ambient temperature **70°F (21°C)**
- FKM (FPM) O-rings
- optional non-closure design available, contact Dixon®



### Female NPT x Female NPT

Size	DN Size	316 Stainless Steel	
		Part #	Price/E
2"	50	<b>MSBC200SS</b>	<b>\$3210.70</b>
3"	80	<b>MSBC300SS</b>	<b>5680.95</b>
4"	100	<b>MSBC400SS</b>	<b>9110.75</b>
5"	125	<b>MSBC500SS</b>	<b>17259.20</b>



### Male NPT x Male NPT

Size	DN Size	316 Stainless Steel	
		Part #	Price/E
2"	50	<b>MSBC200SSMNPT</b>	<b>\$3331.30</b>
3"	80	<b>MSBC300SSMNPT</b>	<b>5926.65</b>
4"	100	<b>MSBC400SSMNPT</b>	<b>9725.50</b>
5"	125	<b>MSBC500SSMNPT</b>	<b>16233.15</b>
6"	150	<b>MSBC600SSMNPT</b>	<b>32438.60</b>



### 150# Flange x 150 Flange

Size	DN Size	316 Stainless Steel	
		Part #	Price/E
2"	50	<b>MSBC200SSFL</b>	<b>\$4923.95</b>
3"	80	<b>MSBC300SSFL</b>	<b>7895.55</b>
4"	100	<b>MSBC400SSFL</b>	<b>11325.30</b>
5"	125	<b>MSBC500SSFL</b>	<b>19382.40</b>
6"	150	<b>MSBC600SSFL</b>	<b>30838.40</b>
8"	200	<b>MSBC800SSFL</b>	<b>63601.75</b>



- For flange dimensions, diagrams and additional information please reference [dixonvalve.com](http://dixonvalve.com).

### How it Works

Safety break-away couplings have three external break bolts. In the case of axial tension all of the bolts take up the force corresponding to the break force on the hose with a safety margin. Non-axial forces concentrate the tension forces more strongly on one bolt, so that the safety break-away coupling reacts in a natural way to the reduction of the hose break forces.



**BEFORE emergency disconnect**

The safety break-away valve consists of two halves, each with a valve that has a O-ring seal.

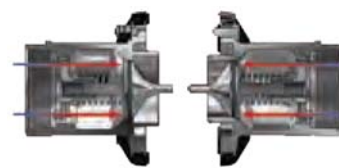

**AFTER emergency disconnect**

When the safety break-away couplings separate, it allows the valves to close. The two valves close rapidly, minimizing exposure to personnel and the environment.

## Mann Tek Safety Break-away Coupling - Industrial Version

**Application:**

- loading rack, bulk loading / unloading, road tankers and rail tankers

**Features:**

- designed to be installed between a fixed point (pipe, pump, manifold) and a hose
- minimizes spillage and damage associated with pull-away incidents
- coupling automatically senses excessive load, closes valves and disconnects, release is executed when force causes bolts to break
- high flow rate / low pressure drop
- working pressure: stainless steel **360 PSI** and aluminum **230 PSI** at ambient temperature **70°F (21°C)**
- FKM (FPM) seal standard
- optional non-closure design available, contact Dixon®

## Female NPT x Female NPT



Size	DN Size	316 Stainless Steel		Aluminum	
		Part #	Price/E	Part #	Price/E
2"	50	<b>SBC200SS</b>	<b>\$2675.55</b>	<b>SBC200AL</b>	<b>\$1380.15</b>
3"	80	<b>SBC300SS</b>	<b>5043.20</b>	<b>SBC300AL</b>	<b>2594.85</b>
4"	100	<b>SBC400SS</b>	<b>7592.25</b>	<b>SBC400AL</b>	<b>3971.85</b>
5"	125	<b>SBC500SS</b>	<b>13527.15</b>	<b>SBC500AL</b>	<b>8602.95</b>
6"	150	<b>SBC600SS</b>	<b>24469.95</b>	<b>SBC600AL</b>	<b>19209.55</b>

## Male NPT x Male NPT



Size	DN Size	316 Stainless Steel		Aluminum	
		Part #	Price/E	Part #	Price/E
2"	50	<b>SBC200SSMNPT</b>	<b>\$2797.30</b>	<b>SBC200ALMNPT</b>	<b>\$1510.20</b>
3"	80	<b>SBC300SSMNPT</b>	<b>4980.35</b>	<b>SBC300ALMNPT</b>	<b>2760.25</b>
4"	100	<b>SBC400SSMNPT</b>	<b>8206.55</b>	<b>SBC400ALMNPT</b>	<b>4137.45</b>
5"	125	<b>SBC500SSMNPT</b>	<b>13527.15</b>	<b>SBC500ALMNPT</b>	<b>8602.95</b>
6"	150	<b>SBC600SSMNPT</b>	<b>28993.75</b>	<b>SBC600ALMNPT</b>	<b>20521.70</b>

## 150# Flange x 150# Flange



Size	DN Size	316 Stainless Steel		Aluminum	
		Part #	Price/E	Part #	Price/E
2"	50	<b>SBC200SSFL</b>	<b>\$4103.25</b>	<b>SBC200ALFL</b>	<b>\$2364.25</b>
3"	80	<b>SBC300SSFL</b>	<b>6579.60</b>	<b>SBC300ALFL</b>	<b>3460.65</b>
4"	100	<b>SBC400SSFL</b>	<b>9437.80</b>	<b>SBC400ALFL</b>	<b>4890.95</b>
5"	125	<b>SBC500SSFL</b>	<b>16854.05</b>	<b>SBC500ALFL</b>	<b>11139.50</b>
6"	150	<b>SBC600SSFL</b>	<b>25698.65</b>	<b>SBC600ALFL</b>	<b>20128.60</b>
8"	200	<b>SBC800SSFL</b>	<b>63601.75</b>	---	---

- For flange dimensions, diagrams and additional information please reference [dixonvalve.com](http://dixonvalve.com).

## Mann Tek TTMA Flanged Breakaway Coupling - Industrial Version

**Features:**

- minimizes spillage and damage associated with drive away and pull away incidents
- installs between an API coupler and loading arm
- coupling automatically senses excessive load, closes the valves and disconnects, release is executed when force causes the bolts to break
- high flow rate / low pressure drop
- 150 PSI** at ambient temperature **70°F (21°C)**
- FKM/FPM is standard seal



Size	Aluminum	
	Part #	Price/E
4"	<b>SBC400ALTTMA</b>	<b>\$4890.95</b>

- For flange dimensions, diagrams and additional information please reference [dixonvalve.com](http://dixonvalve.com).

## FloMAX Diesel Fueling System

**Application:**

- designed for on-site refueling of construction, mining, forestry and agricultural equipment

### Diesel Fuel Nozzles

**Features:**

- 1½" female NPT
- tested to 180 gallons per minute
- integrated high flow swivel and sealing plug
- plug/bumper assembly gives complete nose seal
- investment cast aluminum housing
- anodized aluminum non-wear parts
- stainless steel wear components
- Delron® bushings eliminate metal-to-metal wear
- interchanges with Caterpillar® and Wiggins systems



Description	Part #	Price/E
dog latch mechanism with sealing plug	<b>FN600</b>	<b>\$2517.00</b>
ball lock with sealing plug	<b>FN600BL</b>	<b>2517.00</b>
sealing plug for FN600	<b>FN600B-PLUG</b>	<b>179.80</b>
sealing plug for FN600BL	<b>FN600B</b>	<b>179.80</b>

### One-Piece Diesel Fuel Receivers

**Features:**

- 2" male NPT
- O-ring sealed aluminum cap
- cap has set screw attached vinyl coated cable lanyard

Description	Material	Part #	Price/E
one-piece receiver without cap	<i>nickel-plated steel</i>	<b>FRS</b>	<b>\$350.65</b>
one-piece receiver with cap	<i>nickel-plated steel</i>	<b>FRS-C</b>	<b>404.55</b>
one-piece receiver without cap	<i>anodized aluminum</i>	<b>FRA</b>	<b>350.65</b>
one-piece receiver with cap	<i>anodized aluminum</i>	<b>FRA-C</b>	<b>404.55</b>
cap for receiver	<i>anodized aluminum</i>	<b>FR-CAP</b>	<b>121.40</b>



### Two-Piece Diesel Fuel Receivers

**Features:**

- 2" male NPT
- O-ring sealed aluminum cap
- cap has set screw attached vinyl coated cable lanyard

Description	Part #	Price/E
two-piece receiver with removable stainless sleeve, without cap	<b>FR-RS</b>	<b>\$602.30</b>
two-piece receiver with removable stainless sleeve with cap	<b>FR-RS-C</b>	<b>656.25</b>
removable sleeve replacement for two-piece receiver	<b>FR-RS-R</b>	<b>197.80</b>
cap for receiver	<b>FR-CAP</b>	<b>121.40</b>







## Non-Interchange Diesel Fuel Nozzle

### Application:

- used in biodiesel fueling

### Features:

- 1½" female NPT
- design prevents fuel contamination
- connects to the non-interchange receiver only
- ball lock design

Description	Part #	Price/E
ball lock fuel nozzle	<b>FN600BL-NI</b>	<b>\$2891.25</b>

## Non-Interchange Diesel Fuel Receiver

### Application:

- used in biodiesel fueling

### Features:

- design prevents fuel contamination
- connects to the non-interchange nozzle only
- ball lock design



Description	Anodized Aluminum Part #	Price/E
one-piece receiver with cap	<b>FRA-NI-C</b>	<b>\$464.55</b>

## 2" High Volume Diesel Fueling System

### Features:

- capable of flowing over 400 GPM
- 2" female NPT
- stainless steel ball lock design
- removable pull back assembly

### Materials:

- housing: aluminum
- non-wear parts: anodized aluminum
- internal wear components: stainless steel
- bushings: Delron®

## Diesel Fuel Nozzles



Description	Part #	Price/E
2" fuel nozzle	<b>FX1500<sup>1</sup></b>	<b>\$4483.35</b>
2" fuel nozzle - with plug	<b>FX1500P<sup>1</sup></b>	<b>4636.15</b>
2" fuel nozzle - with swivel	<b>FX1500S<sup>1</sup></b>	<b>4708.10</b>
2" fuel nozzle - with swivel, with plug	<b>FX1500SP<sup>1</sup></b>	<b>4860.90</b>
2" sealing plug for nozzle	<b>FX1500PLUG</b>	<b>213.55</b>

<sup>1</sup> must be used with high flow fuel vents found on page A-17

## Diesel Fuel Receivers



Description	Part #	Price/E
2" diesel fuel receiver	<b>FRX</b>	<b>\$672.00</b>
2" fuel receiver with cap	<b>FRX-C</b>	<b>784.35</b>
2" cap for receiver	<b>FRXCAP</b>	<b>157.35</b>

## Diesel Fuel Gravity Fill Receivers

**Feature:**

- used with the FN600 or FN600BL to convert to gravity fueling

Size	Description	Part #	Price/E
1 3/8"	straight	<b>GFR-0</b>	<b>\$454.00</b>
1 3/8"	45°	<b>GFR-45</b>	<b>481.00</b>
1 3/8"	90°	<b>GFR-90</b>	<b>481.00</b>
1"	straight	<b>GFR1-0</b>	<b>481.00</b>
1"	45°	<b>GFR1-45</b>	<b>503.45</b>
1"	90°	<b>GFR1-90</b>	<b>503.45</b>



Engineered Fluid Transfer Couplings

## Fuel Vents

**Features:**

- 2" male NPT
- billet cap provides superior impact resistance
- easily serviced all metal construction
- rigid ball cage for positive seal
- available with: threaded outlet, half coupling and anti-vandalism mounting

Description	Part #	Price/E
vent with 5" tube	<b>VT</b>	<b>\$418.05</b>
vent with 7" tube	<b>VT7</b>	<b>431.55</b>
vent with 9" tube	<b>VT9</b>	<b>445.00</b>
vent with 5" tube and threaded outlet	<b>VTT</b>	<b>467.50</b>



## High Flow Fuel Vents

**Feature:**

- 7" tubes are available, contact Dixon® for more information

Description	Part #	Price/E
high flow fuel vent with 5" tube	<b>VTX</b>	<b>\$777.60</b>
high flow fuel vent with 9" tube	<b>VTX-9</b>	<b>813.55</b>



## Diesel Fuel Swivels

**Features:**

- stainless steel male threaded base and ball bearings
- hard black anodized female threaded nut
- fluorosilicone sealing O-rings

Thread Size	Description	Part #	Price/E
1 1/2" male NPT x 1 1/2" female NPT	standard	<b>FNS</b>	<b>\$323.65</b>
2" male NPT x 1 1/2" female NPT	standard	<b>FNS2</b>	<b>337.15</b>
1 1/2" female NPT x 1 1/2" female NPT	double	<b>FNSID</b>	<b>364.15</b>
1 1/2" male NPS x 1 1/2" female NPT	standard	<b>FN600S<sup>1</sup></b>	<b>323.65</b>

<sup>1</sup> used with FN600 or FN600BL



FNS - standard

FNSID - double

## Service Box

**Features:**

- Designed to enclose receivers for diesel fuel, hydraulic oil, transmission fluid and coolant reducing contamination and weather related problems.
- normally installed on heavy duty earth mover equipment and drill rigs
- 12 gauge steel construction with heavy duty hinges
- painted with Imron® Primer

Part #	Price/E
<b>FSB</b>	<b>\$1719.95</b>



receivers sold separately

## Standard Series Connectors

**Features:**

- standard series connectors consist of four color-coded mating connectors
- all-metal construction with stainless steel wear components and anodized aircraft grade aluminum non-wear components
- easily recognizable labeling
- fully compatible and interchangeable with industry standards

## Engine Oil Nozzles

**Features:**

- **bright red**
- universally fits both R-series and Standard series crankcase receivers
- incorporates 10 locking balls with a 40% deeper engagement
- resistant to clogging with a greater ease of cleaning
- smooth actuation
- larger diameter pullback lanyard



Male Thread	Description	Anodized Aluminum	
		Part #	Price/E
3/4" NPT	engine nozzle ball lock	<b>ENBL</b>	<b>\$575.35</b>
3/4" NPT	engine nozzle ball lock with plug	<b>ENBL-P</b>	<b>629.30</b>
---	engine nozzle plug	<b>ENBL-PLUG</b>	<b>98.90</b>

## Engine Oil Receivers



ERS-C



ERJ-C

Male Thread	Description	Anodized Aluminum	
		Part #	Price/E
3/4" NPT	engine receiver	<b>ERS</b>	<b>\$247.20</b>
3/4" NPT	engine receiver with cap	<b>ERS-C</b>	<b>305.65</b>
---	engine receiver cap	<b>ERS-CAP</b>	<b>98.90</b>
3/4" JIC	engine receiver with JIC bulkhead base	<b>ERJ</b>	<b>319.15</b>
3/4" JIC	engine receiver with JIC bulkhead base and cap	<b>ERJ-C</b>	<b>373.10</b>

## Coolant Fluid Nozzles

**Features:**

- **bright teal**
- standard roll-pin locking mechanism
- ergonomically engineered pullbacks and caps



Male Thread	Description	Anodized Aluminum	
		Part #	Price/E
1/2" NPT	coolant nozzle ball lock	<b>CN</b>	<b>\$382.10</b>
1/2" NPT	coolant nozzle ball lock with plug	<b>CN-P</b>	<b>436.00</b>
---	coolant nozzle plug	<b>CN-PLUG</b>	<b>98.90</b>

## Coolant Fluid Receivers



Male Thread	Description	Anodized Aluminum	
		Part #	Price/E
1/2" NPT	coolant receiver	<b>CR-S</b>	<b>\$220.30</b>
1/2" NPT	coolant receiver with cap	<b>CR-C</b>	<b>274.20</b>
---	coolant receiver cap	<b>CR-CAP</b>	<b>98.90</b>



### Hydraulic Oil Nozzles

**Features:**

- **bright gold**
- 10 steel dog latching mechanism
- ergonomically engineered pullbacks and caps

Female Thread	Description	Anodized Aluminum	
		Part #	Price/E
3/4" NPT	hydraulic nozzle	<b>HN</b>	<b>\$575.35</b>
3/4" NPT	hydraulic nozzle with plug	<b>HN-P</b>	<b>629.30</b>
---	hydraulic nozzle plug	<b>HN-PLUG</b>	<b>98.90</b>



### Hydraulic Oil Receivers

Male Thread	Description	Anodized Aluminum	
		Part #	Price/E
3/4" NPT	hydraulic receiver	<b>HR</b>	<b>\$463.00</b>
3/4" NPT	hydraulic receiver with cap	<b>HR-C</b>	<b>521.40</b>
---	hydraulic receiver cap	<b>HR-CAP</b>	<b>98.90</b>



### Transmission Fluid Nozzles

**Features:**

- **bright violet**
- 6 steel dog latching mechanism
- ergonomically engineered pullbacks and caps

Male Thread	Description	Anodized Aluminum	
		Part #	Price/E
1/2" NPT	transmission nozzle	<b>TN</b>	<b>\$516.95</b>
1/2" NPT	transmission nozzle with plug	<b>TN-P</b>	<b>570.85</b>
---	transmission nozzle plug	<b>TN-PLUG</b>	<b>98.90</b>



### Transmission Fluid Receivers

Female Thread	Description	Anodized Aluminum	
		Part #	Price/E
3/8" NPT	transmission receiver	<b>TR</b>	<b>\$269.75</b>
3/8" NPT	transmission receiver with cap	<b>TR-C</b>	<b>328.15</b>
---	transmission receiver cap	<b>TR-CAP</b>	<b>98.90</b>





## R Series Connectors

## Features:

- fully compatible and interchangeable with industry standards
- all-metal construction using anodized aircraft grade aluminum non-wear components
- standard roll-pin locking mechanism
- ergonomically engineered pullbacks and caps

## Engine Oil Nozzles

## Feature:

- bright red



Female Thread	Description	Anodized Aluminum	
		Part #	Price/E
3/4" NPT	R-series engine nozzle	<b>R-EN</b>	<b>\$445.00</b>
3/4" NPT	R-series engine nozzle with plug	<b>R-EN-P</b>	<b>498.95</b>
---	R-series engine nozzle plug	<b>R-EN-PLUG</b>	<b>98.90</b>

## Engine Oil Receivers



Male Thread	Female Thread	Description	Anodized Aluminum	
			Part #	Price/E
1.625-12 UN-2A	1.312-12 UN-2B	R-series engine receiver	<b>R-ER</b>	<b>\$193.30</b>
1.625-12 UN-2A	1.312-12 UN-2B	R-series engine receiver with cap	<b>R-ER-C</b>	<b>251.75</b>
---	---	R-series engine receiver cap	<b>R-ER-CAP</b>	<b>98.90</b>

## Coolant Fluid Nozzles

## Feature:

- bright teal



Female Thread	Description	Anodized Aluminum	
		Part #	Price/E
1/2" NPT	R-series coolant nozzle	<b>R-CN</b>	<b>\$418.05</b>
1/2" NPT	R-series coolant nozzle with plug	<b>R-CN-P</b>	<b>471.95</b>
---	R-series coolant nozzle plug	<b>R-CN-PLUG</b>	<b>98.90</b>

## Coolant Fluid Receivers



Male Thread	Female Thread	Description	Anodized Aluminum	
			Part #	Price/E
1.187-12 UN-2A	.875-14 UN-2B	R-series coolant receiver	<b>R-CR</b>	<b>\$161.85</b>
1.187-12 UN-2A	.875-14 UN-2B	R-series coolant receiver with cap	<b>R-CR-C</b>	<b>220.30</b>
---	---	R-series coolant receiver cap	<b>R-CR-CAP</b>	<b>98.90</b>

### Hydraulic Oil Nozzles

**Feature:**

- bright gold

Female Thread	Description	Anodized Aluminum	
		Part #	Price/E
1" NPT	R-series hydraulic nozzle	<b>R-HN</b>	<b>\$485.45</b>
1" NPT	R-series hydraulic nozzle with plug	<b>R-HN-P</b>	<b>543.85</b>
---	R-series hydraulic nozzle plug	<b>R-HN-PLUG</b>	<b>98.90</b>



Engineered Fluid Transfer Couplings

### Hydraulic Oil Receivers

Male Thread	Female Thread	Description	Anodized Aluminum	
			Part #	Price/E
1.875-12 UN-2A	1.625-12 UN-2B	R-series hydraulic receiver	<b>R-HR</b>	<b>\$242.75</b>
1.875-12 UN-2A	1.625-12 UN-2B	R-series hydraulic receiver with cap	<b>R-HR-C</b>	<b>301.20</b>
---	---	R-series hydraulic receiver cap	<b>R-HR-CAP</b>	<b>98.90</b>



### Transmission Fluid Nozzles

**Feature:**

- bright violet

Female Thread	Description	Anodized Aluminum	
		Part #	Price/E
3/4" NPT	R-series transmission nozzle	<b>R-TN</b>	<b>\$395.55</b>
3/4" NPT	R-series transmission nozzle with plug	<b>R-TN-P</b>	<b>449.50</b>
---	R-series transmission nozzle plug	<b>R-TN-PLUG</b>	<b>98.90</b>



### Transmission Fluid Receivers

Male Thread	Female Thread	Description	Anodized Aluminum	
			Part #	Price/E
1.312-12 UN-2A	1.062-12 UN-2B	R-series transmission receiver	<b>R-TR</b>	<b>\$179.80</b>
1.312-12 UN-2A	1.062-12 UN-2B	R-series transmission receiver, cap	<b>R-TR-C</b>	<b>238.25</b>
---	---	R-series transmission receiver cap	<b>R-TR-CAP</b>	<b>98.90</b>



## High Flow 3/4" Series Connectors

## Features:

- 6 nozzle and receiver sets color coded for quick identification of mating parts; each color nozzle and receiver only couples with matching color component providing complete protection against cross contamination
- maximum flow rate: 50 GPM at 40 PSI
- working pressure rating: **200 PSI**

## Nozzles

Male Thread	Description	Anodized Aluminum	
		Part #	Price/E
3/4" NPT	red nozzle with plug	<b>ENBL-P</b>	<b>\$629.30</b>
	gold nozzle with plug	<b>ENBL-P2</b>	<b>629.30</b>
	teal nozzle with plug	<b>ENBL-P3</b>	<b>629.30</b>
	violet nozzle with plug	<b>ENBL-P4</b>	<b>629.30</b>
	navy nozzle with plug	<b>ENBL-P5</b>	<b>629.30</b>
	copper nozzle with plug	<b>ENBL-P6</b>	<b>629.30</b>

## Receivers

Male Thread	Description	Anodized Aluminum	
		Part #	Price/E
3/4" NPT	red receiver with cap	<b>ERS-C</b>	<b>\$305.65</b>
	gold receiver with cap	<b>ERS-C2</b>	<b>305.65</b>
	teal receiver with cap	<b>ERS-C3</b>	<b>305.65</b>
	violet receiver with cap	<b>ERS-C4</b>	<b>305.65</b>
	navy receiver with cap	<b>ERS-C5</b>	<b>305.65</b>
	copper receiver with cap	<b>ERS-C6</b>	<b>305.65</b>

- ERS series is available with JIC bulkhead base, substitute 'J' for 'S', example: ERJ-C2

## High Flow 1" Series Connectors

## Features:

- 7 color coded nozzle and receiver sets for quick identification of mating parts; nozzle and receiver only couple with matching color component providing complete protection against cross contamination
- nozzle/receiver combination has a flow area equivalent to a 1" schedule 80 pipe
- working pressure: **500 PSI** with burst pressure: **1500 PSI**
- all wear parts are stainless steel; all non-wear parts are colored anodized aircraft grade aluminum
- standard nozzle mounting: 1" female NPT; receiver: 1" male NPT
- nozzle incorporates a ball lock mechanism ensuring smooth and reliable operation
- length: nozzle 3.90" (99 mm), receiver 3.44" (87 mm)
- nozzle and receiver coupled length: 5.44" (138 mm)
- diameter: 2.50" (64 mm)
- hex size: 2" (51 mm)

## Nozzles

Female NPT	Description	Anodized Aluminum	
		Part #	Price/E
1"	red nozzle with plug	<b>HFN-P1</b>	<b>\$705.65</b>
	gold nozzle with plug	<b>HFN-P2</b>	<b>705.65</b>
	teal nozzle with plug	<b>HFN-P3</b>	<b>705.65</b>
	violet nozzle with plug	<b>HFN-P4</b>	<b>705.65</b>
	navy nozzle with plug	<b>HFN-P5</b>	<b>705.65</b>
	copper nozzle with plug	<b>HFN-P6</b>	<b>705.65</b>
	blue/gray nozzle with plug	<b>HFN-P7</b>	<b>705.65</b>

## Receivers

Male NPT	Description	Anodized Aluminum	
		Part #	Price/E
1"	red receiver with cap	<b>HFR-C1</b>	<b>\$444.96</b>
	gold receiver with cap	<b>HFR-C2</b>	<b>444.96</b>
	teal receiver with cap	<b>HFR-C3</b>	<b>444.96</b>
	violet receiver with cap	<b>HFR-C4</b>	<b>444.96</b>
	navy receiver with cap	<b>HFR-C5</b>	<b>444.96</b>
	copper receiver with cap	<b>HFR-C6</b>	<b>444.96</b>
	blue/gray receiver with cap	<b>HFR-C7</b>	<b>444.96</b>

FloMAX Part Number Cross Reference

Engineered Fluid  
 Transfer Couplings



**Standard Series Connectors**

**R Series Connectors**

Dixon® Part #	Caterpillar® Part #	Wiggins Part #
Engine Oil Nozzles		
ENBL	9S9273	OS2
ENBL-P	---	OSP2
ENBL-PLUG	9S9274	OP-12
ERJ	---	ON6
Engine Oil Receivers		
ERS	9S9271	ON2
ERS-C	---	ONC2A
ERS-CAP	9S9272	O3B12P
Coolant Fluid Nozzles		
CN	108-5455	EC280B8
CN-P	---	---
CN-PLUG	108-5456	1209-8
Coolant Fluid Receivers		
CR-S	IQ5459	EC285A8
CR-C	---	---
CR-CAP	5P3587	1208-8
Hydraulic Oil Nozzles		
HN	108-5433	6000B12
HN-P	---	---
HN-PLUG	---	6009-12
Hydraulic Oil Receivers		
HR	108-5454	6005A12
HR-C	---	---
HR-CAP	IQ-5468	6008-12
Transmission Fluid Nozzles		
TN	126-7538	C-1807
TN-P	---	---
TN-PLUG	---	P-1844
Transmission Fluid Receivers		
TR	108-5456	P-1804
TR-C	---	---
TR-CAP	SP3587	P-1880

Dixon® Part #	Caterpillar® Part #	Wiggins Part #
Engine Oil Nozzles		
R-EN	---	R15
R-EN-P	---	---
R-EN-PLUG	---	R1507
Engine Oil Receivers		
R-ER	---	R16
R-ER-C	---	---
R-ER-CAP	---	R1605
Coolant Fluid Nozzles		
R-CN	---	R11
R-CN-P	---	---
R-CN-PLUG	---	R1107
Coolant Fluid Receivers		
R-CR	---	R12
R-CR-C	---	---
R-CR-CAP	---	R1205
Hydraulic Oil Nozzles		
R-HN	---	R17
R-HN-P	---	---
R-HN-PLUG	---	R1707
Hydraulic Oil Receivers		
R-HR	---	R18
R-HR-C	---	---
R-HR-CAP	---	R1805
Transmission Fluid Nozzles		
R-TN	---	R13
R-TN-P	---	---
R-TN-PLUG	---	R1307
Transmission Fluid Receivers		
R-TR	---	R14
R-TR-C	---	---
R-TR-CAP	---	R1405

**Diesel Fueling System**

**Fuel Vent Series**

Dixon® Part #	Caterpillar® Part #	Wiggins Part #
VT	6G7803	ZV10
VT7	---	ZV10F
VT9	---	ZV10
VTT	5V6106	ZV10C
VT-C	---	ZV10A
VT-A-7	9G01965	ZV11
VT-A-9	4T1314	ZV11A

Dixon® Part #	Caterpillar® Part #	Wiggins Part #
Nozzles		
FN600	---	ZZF150
FN600BL	---	ZZ9A1
FN600B-PLUG	---	---
Receivers		
FRS	2G9000	ZN2A
FRS-C	---	ZNC2A
FRA	---	ZN2A
FRA-C	---	ZNC2A
FR-CAP	0D0630	ZC20P
FR2	9D0630	---
FR2-C	---	---
FR2-R	---	---
GFR-0	---	ZN6A
GFR-45	---	---
GFR-90	---	ZN6B
GFR1-0	---	ZN6B
GFR1-45	---	---
GFR1-90	---	ZN6B
FNS	---	ZS9
FNS2	---	---
FN600S	---	---
BFN	---	ZS5
BH-F	---	---
FNS10	---	---
FR-SOCKET	---	---
BH-W	---	---

## API Couplers

## Features:

- completely modular coupler can be built with various face seal combinations to be compatible with different alternative fuel / performance levels and applications
- 4" TTMA inlet mounting flange
- 5 cam design for easy alignment and tight connection
- ball-end handle for easy, comfortable operation
- no special tools needed for maintenance
- shaft seals can be changed without removing coupler from loading arm
- link, shaft, pin and crank: hardened 17-4PH stainless steel
- cam: stainless steel
- weight: 20 lbs.
- maximum working pressure: **150 PSI**
- peak surge pressure: **350 PSI**
- maximum flow rate: 1000 GPM
- pressure drop: **3 to 4 PSI**
- replacement parts are available, contact Dixon®



## API Couplers with Bonded Nose Seal

Seal Material	Operating Temperature	Part #	Price/E
<i>Buna</i>	<b>-20°F to 250°F (-29°C to 121°C)</b>	<b>5300</b>	<b>\$2343.25</b>
<i>FKM-B</i>	<b>-10°F to 400°F (-23°C to 204°C)</b>	<b>5300B</b>	<b>2577.60</b>
<i>FKM-GFLT</i>	<b>-20°F to 400°F (-29°C to 204°C)</b>	<b>5300G</b>	<b>2577.60</b>
<i>FKM-B with stainless wave spring</i>	<b>-10°F to 400°F (-23°C to 204°C)</b>	<b>5300BC<sup>1</sup></b>	<b>2636.00</b>
<i>FKM-B with stainless wave spring</i>	<b>-10°F to 400°F (-23°C to 204°C)</b>	<b>5300BCL</b>	<b>2700.00</b>

<sup>1</sup> stainless steel internal springs and is recommended for crude oil service

## API Couplers with Replaceable Nose Seal

Seal Material	Operating Temperature	Part #	Price/E
<i>Buna</i>	<b>-20°F to 250°F (-29°C to 121°C)</b>	<b>5400</b>	<b>\$2343.25</b>
<i>FKM-B</i>	<b>-10°F to 400°F (-23°C to 204°C)</b>	<b>5400B</b>	<b>2577.60</b>
<i>FKM-GFLT</i>	<b>-20°F to 400°F (-29°C to 204°C)</b>	<b>5400G</b>	<b>2577.60</b>

## API Coupler Locking Handle Repair Kit

Description	Part #	Price/E
locking handle kit for 5300BC rack couplers	<b>5354K21</b>	<b>\$234.18</b>

## API Load Only Valves

## Application:

- used for bottom loading and unloading of petroleum tankers, typically mounted to the piping below each tank compartment using the built-in 4" TTMA flange connection



Description	Part #	Price/E
load only API valve without sight glass, ALH nose ring	<b>5204LNG</b>	<b>\$547.50</b>
load only API valve without sight glass, Baylast™ seal, stainless steel springs	<b>5204LSNG</b>	<b>643.75</b>
load only API valve without sight glass, Baylast™ seal, stainless steel springs with ½" FNPT drain port	<b>5204LSNGP</b>	<b>721.00</b>

## API Load/Unload Valves



Description	Part #	Price/E
load/unload API valve with sight glass, ALH nose ring	<b>5204</b>	<b>\$799.00</b>
load/unload API valve, without sight glass, fixed handle, Baylast™ seal	<b>5204NG</b>	<b>777.65</b>



API Drop Adapters

**Application:**

- for offloading through an API adapter

Adapter Size	Coupler Size	Description	Aluminum	
			Part #	Price/E
3"	4" API	with Baylast™ O-ring seal	<b>4530</b>	<b>\$202.00</b>
4"	4" API	with Baylast™ O-ring seal	<b>4540</b>	<b>202.00</b>
4"	4" API	with Buna-N O-ring seal	<b>4540F</b>	<b>347.20</b>



API Drop Adapters with Sight Glass

Adapter Size	Coupler Size	Description	Aluminum	
			Part #	Price/E
3"	4" API	with inline sight glass and Baylast™ flat gasket	<b>4530SG</b>	<b>\$257.00</b>
4"	4" API	with inline sight glass and Baylast™ flat gasket	<b>4540SG</b>	<b>259.45</b>



API Gravity Drop Adapters

Adapter Size	Coupler Size	Description	Aluminum	
			Part #	Price/E
3"	4" API	with flat Buna gasket	<b>31440-225AL</b>	<b>\$183.80</b>
4"	4" API	with flat Buna gasket	<b>41440-225AL</b>	<b>189.60</b>



API Drop Adapter Repair Kits

Description	Part #	Price/E
replacement cam arms, pins and Baylast™ O-ring seal (standard)	<b>4500RK</b>	<b>\$27.60</b>
replacement cam arms, pins and FKM O-ring seal (optional)	<b>4500RK-V</b>	<b>48.30</b>
replacement 18" chain and S hook	<b>5205-RK4</b>	<b>11.10</b>
sight glass repair kit (fits 3" and 4")	<b>4540SG-RK1</b>	<b>67.55</b>
flat replacement Baylast gasket for 4530SG, 4540SG	<b>4540SG-RK2</b>	<b>8.80</b>
replacement cam arms and pins (fits 3" and 4")	<b>4540SG-RK3</b>	<b>30.80</b>
Baylast O-ring replacement seal for 4530, 4540, 5000-24	<b>4500-5</b>	<b>7.30</b>
flat replacement gasket for 31440-225AL, 41440-225AL, 41450-DCAL	<b>2143SEALBU</b>	<b>13.00</b>

API Dust Caps

Size	Description	Aluminum		Optional Qty
		Part #	Price/E	
4" API	with flat Buna gasket and brass cam arms	<b>41450-DCAL</b>	<b>\$159.00</b>	5
	with O-ring Baylast™ seal and brass cam arms	<b>5000-24</b>	<b>127.90</b>	10
	with locking arms	<b>5000-24L</b>	<b>131.85</b>	1



Adapter Size	Description	Nylon		Optional Qty
		Part #	Price/E	
4" API	with flat Buna seal and plated steel pad lockable roller lever	<b>5000-25</b>	<b>\$89.50</b>	20





4540DC



4540DC-1200

### Gravity Drop Adapter Dust Caps

**Features:**

- designed to fit on any 4" cam and groove adapter, specifically 4" gravity drop adapters
- reduce weight
- easy Pull Off / Push On operation
- Buna gasket
- NOT intended to be pressurized

Size	Black Nylon	
	Part #	Price/E
4"	<b>4540DC</b>	<b>\$96.15</b>
4"	<b>4540DC-1200<sup>1</sup></b>	<b>109.00</b>

<sup>1</sup> supplied with chain

### Dixon Bayco Adapter with Grounding Tab



Size	Description	356T6 Aluminum	
		Part #	Price/E
4"	male adapter with grounding tab	<b>400-C-ALGT</b>	<b>\$111.15</b>

### Dixon Bayco Coupler with Grounding Tab



Size	Description	356T6 Aluminum	
		Part #	Price/E
4"	female coupler with grounding tab	<b>400-E-ALGT</b>	<b>\$75.80</b>

### API Compatible Loading Rack Cords

**Features:**

- highly visible safety orange jacket meets trip hazard requirements
- cord is bonded mechanically and resistant to abrasion and oil
- Cord sets are interchangeable with Scully and Civacon. All wiring is compatible with standard Scully color codes and wiring number configurations. The 9 pin conductor is shielded to be compatible with Scully VIP system.
- plug body is reinforced nylon and is color coded Optic Blue or Thermistor Green
- button contacts are 316 stainless steel to prevent corrosion or galling
- all other hardware is stainless steel

#### API Optic Cord Assemblies



Description	Part #	Price/E
plug with 30' coiled cable, 6 contact pins, 3 J slots	<b>FT620</b>	<b>\$1099.15</b>
plug with 20' straight cable, 6 contact pins, 3 J slots	<b>FT620S</b>	<b>1045.95</b>
plug with 30' coiled cord, 6 contact pins, 3 J slots, J560 plug	<b>FT620P</b>	<b>1305.00</b>
replacement plug assembly with 6 contact pins, 3 J slots	<b>FT621</b>	<b>585.05</b>
replacement 30' coiled cable, optic 6 conductor	<b>FT622</b>	<b>620.00</b>
plug storage hanger	<b>FT623</b>	<b>340.45</b>
replacement 20' straight cord, optic 6 conductor	<b>FT624</b>	<b>1050.00</b>



API Thermistor Cord Assemblies

Description	Part #	Price/E
plug with 30' coiled cable, 8 contact pins, 2 J slots	<b>FT600</b>	<b>\$1099.15</b>
plug with 30' coiled cable, 8 contact pins, 2 J slots, 13 pin connector	<b>FT600P</b>	<b>1439.39</b>
plug with 30' coiled cord, 10 contact pins, 2 J slots (for Canada)	<b>FT600C</b>	<b>1099.15</b>
plug with 20' straight cable, 8 contact pins, 2 J slots	<b>FT600S</b>	<b>1045.95</b>
plug with 30' coiled cable, 10 contact pins, 4 J slots	<b>FT600CP</b>	<b>1439.40</b>
plug with 20' straight cable, 10 contact pins, 4 J slots (for Canada)	<b>FT600SC</b>	<b>1045.95</b>
replacement plug assembly with 8 contact pins, 2 J slots	<b>FT601</b>	<b>568.00</b>
replacement plug assembly with 10 contact pins, 4 J slots (for Canada)	<b>FT601-10</b>	<b>568.00</b>
replacement 30' coiled cable, Thermistor 10 conductor	<b>FT602</b>	<b>620.00</b>
plug storage hanger	<b>FT603</b>	<b>330.50</b>
replacement 20' straight cord, Thermistor 10 conductor	<b>FT604</b>	<b>825.00</b>



API Rack Cord Assemblies

FloTech Part #	Civacon Part #	Scully Part #	API		Cord		J-Slots			Pins		Breakaway Plug	
			Thermistor	Optic	20' Straight	30' Coiled	2	3	4	6	8	10	Optic "J560" Aluminum
<b>FT600</b>	7300SR-7300	21818	✓			✓	✓				✓		
<b>FT600-4</b>			✓			✓				✓	✓		
<b>FT600C</b>	7300CSR-7300	31092	✓			✓					✓		
<b>FT600C-2</b>	7300C-7300		✓			✓	✓				✓		
<b>FT600P</b>	7320SR-7320		✓			✓	✓				✓		✓
<b>FT600P-4</b>			✓			✓				✓	✓		✓
<b>FT600S</b>	7300-STRAIGHT	20830	✓		✓		✓				✓		
<b>FT600SC</b>	7300C-STRAIGHT		✓		✓					✓		✓	
<b>FT600CP</b>			✓			✓				✓	✓		✓
<b>FT600SP</b>			✓				✓				✓		✓
<b>FT605C</b>				✓		✓				✓	✓		
<b>FT620</b>	7100SR-7100	21831		✓		✓		✓		✓			
<b>FT620P</b>	7100-J560			✓		✓		✓		✓		✓	
<b>FT620X620</b>				✓		✓		✓		✓			
<b>FT620S</b>	7100-STRAIGHT	21764		✓	✓			✓		✓			

API Rack Cord Parts

FloTech Part #	Civacon Part #	Scully Part #	API		Cord		J-Slots			Pins			
			Thermistor	Optic	20' Straight	30' Coiled	2	3	4	6	8	10	
<b>FT601</b>	7310SR-7310		✓					✓				✓	
<b>FT601-4</b>			✓							✓		✓	
<b>FT601-10</b>			✓							✓			✓
<b>FT602</b>			✓				✓						
<b>FT603</b>	7350-7350		✓							✓			
<b>FT604</b>			✓		✓								
<b>FT621</b>	7110SR-7110	21766		✓					✓			✓	
<b>FT622</b>	7220-7220	31099		✓					✓				
<b>FT623</b>	7150-7150			✓					✓				
<b>FT624</b>		31098		✓	✓	✓							

Dixon® Vapor Recovery Couplers

- not intended for liquid service, for vapor recovery *only* 

**Materials:**

- body: cast aluminum
- arms: bronze with stainless steel pins
- finger rings: plated carbon steel
- gasket: Buna-N

Dixon® Vapor Recovery Coupler with Probe x Adapter



Coupler Size	Adapter Size	356T6 Aluminum	
		Part #	Price/E
4"	3"	<b>4030-DAVR-AL</b>	<b>\$139.50</b>

Dixon® Vapor Recovery Coupler with Probe x Coupler with Probe



Coupler Size	Coupler Size	356T6 Aluminum	
		Part #	Price/E
4"	4"	<b>400-DDVR-AL</b>	<b>\$160.00</b>

Dixon® Vapor Recovery Coupler with Probe x Hose Shank



VR4030CS-AL

**Applications:**

- for use with 3" vapor hose
- not intended for liquid service, for vapor recovery *only* 

**Features:**

- cast aluminum body, bronze arms with stainless steel pins and finger rings
- Buna-N gasket
- VR4030CS-AL has an FKM O-ring poppet seal
- Dixon® replacement handle assemblies will not work on these fittings, contact Dixon® for replacements.* 



VRC.3000AL

Coupler Size	Hose Shank Size	Description	Part #	Price/E
3"	3"	---	<b>VRC3000AL</b>	<b>\$144.05</b>
4"	2"	---	<b>4020-CVR-AL</b>	<b>128.00</b>
4"	3"	no poppet	<b>4030-CVR-AL</b>	<b>129.10</b>
4"	3"	poppet	<b>VR4030CS-AL</b> <sup>1</sup>	<b>213.25</b>
4"	3"	floating bridge poppet	<b>VR4030CS-SH</b> <sup>2</sup>	<b>584.00</b>
4"	4"	no poppet	<b>400-CVR-AL</b>	<b>137.00</b>
4"	4"	floating bridge poppet	<b>VR4040CS-AL</b> <sup>2</sup>	<b>412.00</b>

<sup>1</sup> interchanges with all competitor vapor valves *except* Civacon #633LVH (special bulb design). 

<sup>2</sup> superior interface with air interlock

**Repair Kits**



4030-CVR-AL

Description	Part #	Price/E
seal repair kit: gasket, machine screw and FKM O-ring	<b>VR4040CSRK1</b>	<b>\$21.35</b>
cam arm repair kit: paddle arm and cam arm pin	<b>VR4040CSRK2</b>	<b>74.35</b>

## Dixon® Vapor Recovery Coupler x 45° Hose Shank

**NEW**



**Features:**

- 'floating bridge' poppet design allows optimal flow
- machined hose shank ensures easier insertion into hose and better sealing
- durable, easy to couple stainless cam arms
- big wings ensure contact with air interlock button on tanker helping prevent drive-offs
- change poppet seal without removing the coupler from the hose
- secure to hose with traditional band clamps or built in crimp collar
- 4" MNPT version allows for either cam and groove or threaded flange option
- seal: Buna N
- not intended for liquid service, for vapor recovery *only* 

Coupler Size	Hose Shank Size	Aluminum	
		Part #	Price/E
4"	3"	<b>VR4030CS-AL45</b>	<b>\$683.00</b>
	4"	<b>VR4040CS-AL45</b>	<b>683.00</b>

## Dixon® Vapor Recovery with Probe Coupler x Female NPT

- not intended for liquid service, for vapor recovery *only* 

**Materials:**

- body: cast aluminum
- arms: bronze with stainless steel pins
- finger rings: plated carbon steel
- gasket: Buna-N



Coupler Size	Female NPT Size	356T6 Aluminum	
		Part #	Price/E
4"	3"	<b>4030-DVR-AL</b>	<b>\$155.00</b>
	4"	<b>400-DVR-AL</b>	<b>157.30</b>





## Tank Truck Flanged Tee

Size	356T6 Aluminum	
	Part #	Price/E
4"	<b>400-TLT-AL</b>	<b>\$255.00</b>

- For flange dimensions, diagrams and additional information please reference [dixonvalve.com](http://dixonvalve.com).

## TTMA Series Flange Adapters

## Features:

- simply and easily converts threaded components to a standard TTMA flange configuration
- solid cast lightweight aluminum design is more durable than welded fabrications
- design improves flow through adapter
- compact size reduces the overall space needed to install

## TTMA Flange x Male NPT Adapters



TTMA Flange	Male NPT	Overall Length	Aluminum	
			Part #	Price/E
3"	3"	2½"	<b>TTF3AL-3MT</b>	<b>\$87.50</b>
4"	3"	2½"	<b>TTF4AL-3MT</b>	<b>65.90</b>
4"	4"	2½"	<b>TTF4AL-4MT</b>	<b>61.10</b>

## TTMA Flange x Extended Length Male NPT Adapters



TTMA Flange	Male NPT	Overall Length	Aluminum	
			Part #	Price/E
4"	3"	5½"	<b>TTF4AL-3EMT</b>	<b>\$87.50</b>
	4"	5½"	<b>TTF4AL-4EMT</b>	<b>102.15</b>

## TTMA Flange x Female NPT Adapter



TTMA Flange	Female NPT	Overall Length	Aluminum	
			Part #	Price/E
4"	3"	2½"	<b>TTF4AL-3FT</b>	<b>\$78.35</b>
	4"	2½"	<b>TTF4AL-4FT</b>	<b>78.05</b>

## TTMA Slip-on Socket Weld Flange



TTMA Flange	Pipe Size	356T6 Aluminum	
		Part #	Price/E
4"	4"	<b>TTF400SP</b>	<b>\$67.00</b>

## TTMA Slip-on Plate Flange



TTMA Flange	Pipe Size	Aluminum	
		Part #	Price/E
4"	4"	<b>TTMA-64</b>	<b>\$29.75</b>

## TTMA Buttweld Flange



TTMA Flange	Pipe Size	Thickness	Aluminum	
			Part #	Price/E
3"	4"	⅜"	<b>TTF3AL</b>	<b>\$26.58</b>
4"	4"	⅜"	<b>TTF4AL</b>	<b>33.29</b>

- For flange dimensions, diagrams and additional information please reference [dixonvalve.com](http://dixonvalve.com).

TTMA Flange Spacer with 1/2" Port

Size	Description	Aluminum	
		Part #	Price/E
4"	flange spacer with 1/2" female NPT port	<b>TTFS4AL-FP50</b>	<b>\$185.60</b>



TTMA Flange Extensions

**Application:**

- used on load arms to connect an API load coupler to a load arm

**Features:**

- adds a 6" space between the load arm and the tank truck
- extension with groove provides a specified parting point to prevent excessive damage to the loading arm

Size	Description	Aluminum	
		Part #	Price/E
4"	TTMA flange extension	<b>TETF4AL</b>	<b>\$130.00</b>
4"	TTMA flange extension with groove	<b>TETFG4AL</b>	<b>133.50</b>
4"	TTMA flange extension with 1/2" female NPT port	<b>TETF4ALFP50</b>	<b>304.85</b>



TETF4AL



TETFG4AL

- For flange dimensions, diagrams and additional information please reference dixonvalve.com.

Dixon™ Adapters and Couplers x TTMA

**Features:**

- aluminum flanges have a flat face, stainless flanges have a raised face
- reference dixonvalve.com for flange drilling standards
- pressure rating is based on the seal of the mating part, see ratings on page D-5

Size	356T6 Aluminum		316 Stainless Steel	
	Part #	Price/E	Part #	Price/E
3"	<b>300-ALT-AL</b>	<b>\$78.25</b>	<b>300-ALT-SS<sup>1</sup></b>	<b>\$480.00</b>
3" x 4"	<b>3040ALTAL</b>	<b>112.80</b>	---	---
4"	<b>400-ALT-AL</b>	<b>84.70</b>	<b>400-ALT-SS<sup>1</sup></b>	<b>750.00</b>
6"	<b>600-ALT-AL</b>	<b>236.00</b>	---	---



<sup>1</sup> parts are produced as a welded fabrication

Cam & Groove Coupler x TTMA Flange

**Features:**

- supplied standard with a Buna-N gasket, other gaskets available on pages D-48 to D-50
- use Dixon® replacement handles only

Size	356T6 Aluminum	
	Part #	Price/E
3"	<b>300-DLT-AL</b>	<b>\$142.60</b>
3" x 4"	<b>3040DLTAL</b>	<b>159.40</b>
4"	<b>400-DLT-AL</b>	<b>167.00</b>
6"	<b>600-DLT-AL</b>	<b>350.00</b>



- For flange dimensions, diagrams and additional information please reference dixonvalve.com.

Cam & Groove 22 1/2° Adapter x TTMA Flange

**Feature:**

- pressure rating is based on the seal of the mating part, see ratings on page D-5

Size	356T6 Aluminum	
	Part #	Price/E
4"	<b>40022ALTAL</b>	<b>\$186.30</b>



Cam & Groove 22 1/2° Coupler x TTMA Flange

**Features:**

- supplied standard with a Buna-N gasket, other gaskets available on pages D-48 to D-50
- use Dixon® replacement handles only

Size	356T6 Aluminum	
	Part #	Price/E
4"	<b>40022DLTAL</b>	<b>\$153.60</b>



- For flange dimensions, diagrams and additional information please reference dixonvalve.com.



## TTMA Flange Gaskets

Size	OD	ID	Thick.	Material	Part #	Price/E
3"	5-5/8"	3-1/2"	1/8"	Cork / Buna	<b>300GTTFCB</b>	<b>\$3.90</b>
	5-5/8"	3-1/2"	1/16"	PTFE envelope with Klinger filler	<b>300GTTFTK</b>	<b>17.25</b>
	5-5/8"	3-1/2"	1/8"	Klingersil® C-4300	<b>300GTTFK</b>	<b>9.95</b>
	5-29/32"	3-1/2"	3/32"	PTFE with fiber core	<b>40321TF</b>	<b>22.65</b>
	7-1/4"	5"	5/32"	PTFE with soft fiber core	<b>40364TF</b>	<b>95.45</b>
	7-1/4"	5"	1/8"	Baylast™	<b>40364BL</b>	<b>20.61</b>
	5-5/8"	3-5/8"	1/8"	Baylast™	<b>300GTTFBL</b>	<b>20.50</b>
4"	6-5/8"	4-9/16"	1/8"	Cork / Buna	<b>400GTTFCB</b>	<b>4.60</b>
	6-5/8"	4-9/16"	1/16"	PTFE envelope with Klinger filler	<b>400GTTFTK</b>	<b>23.00</b>
	6-5/8"	4-9/16"	1/8"	Klingersil® C-4401	<b>400GTTFK</b>	<b>18.25</b>
	6-7/8"	4-9/16"	3/32"	PTFE with fiber core	<b>40322TF</b>	<b>42.30</b>
	8-3/8"	5-7/8"	5/32"	PTFE with soft fiber core	<b>40323TF</b>	<b>70.00</b>
	8-1/4"	5-7/8"	1/8"	Baylast™	<b>40323BL</b>	<b>25.61</b>
	6-5/8"	4-5/8"	1/8"	Baylast™	<b>400GTTFBL</b>	<b>25.50</b>

- For flange dimensions, diagrams and additional information please reference [dixonvalve.com](http://dixonvalve.com).

## Sight Flow Indicators

## Features:

- Due to the proprietary blending of petroleum products, Dixon® recommends that thermoplastic tubing and gaskets be immersion tested in the product to be handled to ensure compatibility (not compatible with crude oil).
- for dimensional information on tank truck flange drilling reference [dixonvalve.com](http://dixonvalve.com)
- maximum flange bolt torque is 200 in-lb (inch pounds)



## TTMA Flanged Short Sight Flow Indicators

## Features:

- durable cast aluminum housing, replaces competitions all acrylic sight glass as commonly found on tank trucks
- allows for visual identification of the fuel grade prior to opening the valve
- works with tank truck flanged butterfly valves found on gasoline trucks
- low cost sight glass tube can be easily replaced
- rated to **150 PSI**



Size	Width	Aluminum	
		Part #	Price/E
3"	1 3/4"	<b>5200-SFI-3</b>	<b>\$165.55</b>
4"	1 3/4"	<b>5200-SFI</b>	<b>180.95</b>

## TTMA Flanged Sight Flow Indicators

## Features:

- allows for visual identification of the fuel grade prior to opening the valve
- works with tank truck flanged butterfly valves found on gasoline trucks
- larger ID 4 3/8" flow indicator allows tank truck flanged butterfly valves to connect to either end of the indicator
- pressure rating: **150 PSI**



Size	Width	ID	Aluminum	
			Part #	Price/E
4"	3 1/4"	4 3/8"	<b>5201-SFI</b>	<b>\$256.25</b>

## Features:

- allows for visual identification of the fuel grade prior to opening the valve
- 4" flow diameter



Size	ID	Aluminum	
		Part #	Price/E
4"	4 3/8"	<b>4-1460-AL</b>	<b>\$190.10</b>

- For flange dimensions, diagrams and additional information please reference [dixonvalve.com](http://dixonvalve.com).



TTMA Flanged Sight Flow Indicators

Size	Nominal Width	Acrylic	
		Part #	Price/E
3"	1 3/4"	<b>TT3ASG</b>	<b>\$116.00</b>
4"	1 3/4"	<b>TT4ASG</b>	<b>116.00</b>
3"	1 3/4"	<b>TT3ASG-ETH<sup>1</sup></b>	<b>370.00</b>
4"	1 3/4"	<b>TT4ASG-ETH<sup>1</sup></b>	<b>370.00</b>

Optically Enhanced Sight Glass

Size	Nominal Width	Acrylic	
		Part #	Price/E
3"	1 3/4"	<b>TT3ASGOE</b>	<b>\$130.00</b>
4"	1 3/4"	<b>TT4ASGOE</b>	<b>130.00</b>
3"	1 3/4"	<b>TT3ASG-ETHOE<sup>1</sup></b>	<b>370.00</b>
4"	1 3/4"	<b>TT4ASG-ETHOE<sup>1</sup></b>	<b>370.00</b>



<sup>1</sup> for use with ethanol

- For flange dimensions, diagrams and additional information please reference [dixonvalve.com](http://dixonvalve.com).

Sight Flow Indicator Repair Kits

Description	Used on	Part #	Price/E
3" replacement sight glass, Baylast™ O-ring and retainer ring kit	---	<b>5200-SFI-3-RK1</b>	<b>\$80.75</b>
3" replacement sight glass, FKM O-ring and retainer ring kit	---	<b>5200-SFI-3V-RK1</b>	<b>149.60</b>
4" replacement sight glass, Baylast™ O-ring and retainer ring kit	---	<b>5200-SFI-RK1</b>	<b>80.75</b>
4" replacement sight glass, FKM O-ring and retainer ring kit	---	<b>5200-SFIV-RK1</b>	<b>149.60</b>
replacement Baylast O-rings, sight glass and retaining ring	5201-SFI	<b>5201-SFI-RK1</b>	<b>84.45</b>
Buna-N O-ring	---	<b>O249BU</b>	<b>4.75</b>
plexiglass insert	---	<b>4PSG</b>	<b>84.00</b>
Buna-N O-ring	---	<b>O246BU</b>	<b>4.25</b>



5200-SFIV-RK1

TTMA Flange Screen

Feature:

- stainless steel screen is encapsulated in an FKM gasket

Male NPT	Description	Stainless Steel	
		Part #	Price/E
2"	screen with 1" square holes	<b>TTFS4SS</b>	<b>\$150.00</b>



- For flange dimensions, diagrams and additional information please reference [dixonvalve.com](http://dixonvalve.com).

## Tank Transport Fusible Pipe Caps



Size	Stainless Steel <sup>1</sup>		Aluminum		Iron		Optional Qty
	Part #	Price/E	Part #	Price/E	Part #	Price/E	
3"	<b>300-SFC-SS</b>	<b>\$118.90</b>	<b>300-SFC-AL</b>	<b>\$125.53</b>	<b>300-SFC-MI</b>	<b>\$120.00</b>	10

<sup>1</sup> PTFE gaskets are standard in stainless steel fittings.

## Tank Transport Pipe Caps



Size	Stainless Steel <sup>1</sup>		Aluminum		Iron		Optional Qty
	Part #	Price/E	Part #	Price/E	Part #	Price/E	
2"	<b>200-PC-SS</b>	<b>\$121.00</b>	---	---	<b>200-PC-MI</b>	<b>\$40.00</b>	---
3"	<b>300-PC-SS</b>	<b>89.75</b>	<b>300-PC-AL</b>	<b>\$44.75</b>	<b>300-PC-MI</b>	<b>50.40</b>	10
4"	<b>400-PC-SS</b>	<b>248.00</b>	---	---	---	---	---

<sup>1</sup> PTFE gaskets are standard in stainless steel fittings.

## Tank Transport Reducers



Female NPSM	Male NPT	Stainless Steel <sup>1</sup>		Aluminum		Iron		Optional Qty
		Part #	Price/E	Part #	Price/E	Part #	Price/E	
3"	2"	<b>3020-RD-SS</b>	<b>\$140.00</b>	<b>3020-RD-AL</b>	<b>\$85.00</b>	<b>3020-RD-MI</b>	<b>\$58.00</b>	10
4"	3"	<b>4030-RD-SS<sup>2</sup></b>	<b>570.00</b>	<b>4030-RD-AL</b>	<b>128.00</b>	---	---	---

<sup>1</sup> PTFE gaskets are standard in stainless steel fittings.

<sup>2</sup> welded fabrication

## Tank Transport Reducing Cap



Size	Stainless Steel <sup>1</sup>		Optional Qty
	Part #	Price/E	
3" x 1"	<b>3010-RC-SS</b>	<b>\$196.00</b>	10

<sup>1</sup> PTFE gaskets are standard in stainless steel fittings.

## Coupling Gaskets



Buna-N



PTFE

Size	Buna-N		Opt Qty	PTFE		Optional Qty
	Part #	Price/E		Part #	Price/E	
1½"	---	---	--	<b>150GPCTF</b>	<b>\$5.70</b>	--
2"	<b>200GPCBU</b>	<b>\$2.10</b>	25	<b>200GPCTF</b>	<b>4.95</b>	10
3"	<b>300GPCBU</b>	<b>2.35</b>	25	<b>300GPCTF</b>	<b>6.45</b>	25
4"	---	---	--	<b>400GPCTF</b>	<b>15.00</b>	--



Intermodal Tank Transport Pipe Caps

Size	Aluminum		Stainless Steel <sup>1</sup>		Optional Qty
	Part #	Price/E	Part #	Price/E	
3"	<b>300PCALAP</b>	<b>\$59.95</b>	<b>300PCSSAP</b>	<b>\$102.50</b>	10

<sup>1</sup> PTFE gaskets are standard in stainless steel fittings



Intermodal Tank Transport Thread Adapters

Female BSPP	Male NPT	Stainless Steel <sup>1</sup>	
		Part #	Price/E
3"	2"	<b>3020RDSSAP</b>	<b>\$175.00</b>
	3"	<b>3030RDSSAP</b>	<b>255.00</b>

<sup>1</sup> PTFE gaskets are standard in stainless steel fittings



Intermodal Tank Transport Cam & Groove Adapter

Size	Stainless Steel <sup>1</sup>	
	Part #	Price/E
3"	<b>300ASSAP</b>	<b>\$152.00</b>

<sup>1</sup> PTFE gaskets are standard in stainless steel fittings



6200 Series Side Lever Type Drop Elbows

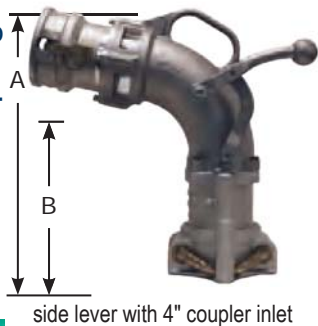

Features:

- cast aluminum modular construction
- brass handle and cam arms with buna gasket
- stainless steel bolts on inlet end
- acrylic sight glass with buna seals
- for information on additional elbow configurations such as pre-assembled elbows, contact Dixon®

Size	Inlet	A Overall Height	B Ground Clearance	Aluminum	
				Part #	Price/E
4"	elbow only, <i>without inlet connection</i>	17¾"	10⅞"	<b>6200</b>	<b>\$933.70</b>
	elbow with 4" adapter inlet			<b>6200A</b>	<b>1049.55</b>
	elbow with anti-spill sleeve, <i>without inlet connection</i>			<b>6200T</b>	<b>1016.40</b>
	elbow with 4" coupler inlet			<b>6200D</b>	<b>1134.25</b>
4"	tall elbow only, <i>without inlet connection</i>	21"	13¾"	<b>6200X</b>	<b>1042.50</b>
	tall elbow with 4" adapter inlet			<b>6200XA</b>	<b>1175.90</b>
	tall elbow with anti-spill sleeve, <i>without inlet connection</i>			<b>6200XT</b>	<b>1131.10</b>
	tall elbow with 4" coupler inlet			<b>6200XD</b>	<b>1249.30</b>

side lever with 4" coupler inlet



side lever without inlet connection

6500 Series Self-Locking Drop Elbows



Size	Inlet	A Overall Height	B Ground Clearance	Aluminum	
				Part #	Price/E
4"	tightfill elbow with locking handle	17¾"	10⅞"	<b>6500</b>	<b>\$988.35</b>
4"	tightfill elbow with locking handle and 4" adapter inlet	17¾"	10⅞"	<b>6500A</b>	<b>1042.75</b>

Male Adapter Inlets



Inlet Size	Aluminum	
	Part #	Price/E
3"	<b>6000-16</b>	<b>\$99.90</b>
4"	<b>6000-17</b>	<b>99.90</b>

Female Coupler Inlets



Inlet Size	Aluminum	
	Part #	Price/E
3"	<b>6000-15</b>	<b>\$183.15</b>
4"	<b>6000-14</b>	<b>183.15</b>

Female NPT Inlet



Inlet Size	Aluminum	
	Part #	Price/E
4"	<b>6000-20</b>	<b>\$100.05</b>

## Dual Point Vapor Recovery Elbows - Ball Lever

**Features:**

- for use in two point vapor recovery systems
- one-piece locking arms
- advanced design side lever locking system
- bolt on 3" male outlet included (**VR6000-6**) which can be rotated for extended life
- lubrication fitting on locking stem
- see below for 6400 series co-axial elbow for single point vapor recovery

**Materials:**

- seals: buna
- hardware: stainless steel
- bronze locking arms housed in polymer bushings



Description	Aluminum	
	Part #	Price/E
3" male adapter with probe, without poppet valve	<b>VR6200NP</b>	<b>\$732.80</b>
3" male adapter outlet with probe and poppet valve	<b>VR6200</b>	<b>834.35</b>

### Adapter Inlet

Description	Aluminum	
	Part #	Price/E
outlet adapter with outlet O-ring	<b>VR6000-6</b>	<b>\$63.35</b>



## Single Point Coaxial Drop Elbow

**Features:**

- for single point vapor recovery only
- 3" male vapor outlet (top)
- comes assembled with 4" male inlet
- bolt-on inlets/outlets for easy, fast replacement
- replacement parts are available, please contact Dixon®
- 6400 co-axial inlets do not fit our other elbow series

**Materials:**

- arms: solid bronze
- sight glass: acrylic
- seals: buna

Inlet	Outlet	Aluminum	
		Part #	Price/E
4" male	3" male vapor	<b>6400</b>	<b>\$1363.95</b>

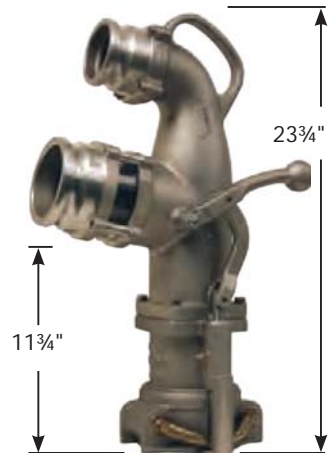

## Coaxial Elbow Adapter Fuel Inlets

**Features:**

- for use with 6400 series coaxial elbows only
- rated for petroleum service, Ethanol to E100 and biodiesel to B20

Size	Aluminum	
	Part #	Price/E
3"	<b>6000-16C</b>	<b>\$99.90</b>
4"	<b>6000-17C</b>	<b>99.90</b>



## Coaxial Elbow Coupler Fuel Inlets

**Features:**

- for use with 6400 series coaxial elbows only
- rated for petroleum service, Ethanol to E100 and biodiesel to B20

Size	Aluminum	
	Part #	Price/E
3"	<b>6000-15C</b>	<b>\$183.15</b>
4"	<b>6000-14C</b>	<b>183.15</b>



## Tank Truck Fittings: Fuel Elbows, Adapters &amp; Couplers

## Tight Fill Drop Elbows - Complete Unit

**Materials:**

- body: aluminum
- handle and cam arms: brass
- gasket: buna
- bolts on inlet end: steel
- sight flow insert: plexiglass

Coupler Size	Inlet	Aluminum	
		Part #	Price/E
3"	3" male adapter	<b>300300MAE</b>	<b>\$694.00</b>
	4" male adapter	<b>3004030MAE</b>	<b>726.00</b>

## Tight Fill Drop Elbow Coupler Body



Size	Aluminum	
	Part #	Price/E
3"	<b>300-TFG</b>	<b>\$650.00</b>

## Tight Fill Male Adapter Inlet End



Inlet	Aluminum	
	Part #	Price/E
3"	<b>300-MAE</b>	<b>\$71.00</b>
4"	<b>4030-MAE</b>	<b>105.00</b>

## Side Seal Drop Elbow

**Features:**

- for use with special 4" side seal style fill collars only
- modular, easy to repair, bolt together construction
- standard with acrylic sight glass with buna seals (2), bronze locking levers and buna main seal
- 4" male adapter inlet and lock ring installed
- replacement parts are available, contact Dixon®

Part #	Aluminum	
	Price/E	
<b>6000ASAL</b>	<b>\$829.75</b>	

## Side Seal to Top Seal Adapter

**Features:**

- allows conventional elbows to be used with special side seal style fill collars
- bottom connects to side seal fill collar
- top section with standard 4" top seal collar profile accepts clamping of standard 4" drop elbows
- replacement parts are available, contact Dixon®

Size	Aluminum	
	Part #	Price/E
4"	<b>6000-SSA</b>	<b>\$377.15</b>

### Dust Cap with Pull Handle for Hose Tubes

**Features:**

- Pull handles make it easier for tanker operators to remove delivery hoses from the storage tubes; the operator simply grabs the handle and easily pulls the hose out of the storage tube.
- Rugged construction protects the hose coupling and adapter from damage during transportation and removal of hoses from the hose storage tube.
- prevents possible environmental issues due to leaking residue left in an open hose

**Materials:**

- aluminum body
- cam arms (dust caps): brass
- seals: buna



4"

Size	Aluminum	
	Part #	Price/E
3"	<b>300-DC-ALPH</b>	<b>\$79.80</b>
4"	<b>400-DC-ALPH</b>	<b>91.85</b>

### Dust Plug with Pull Handle for Hose Tubes

Dust caps and dust plugs are not to be used in pressure applications for safety and environmental reasons.



3"

Size	Aluminum	
	Part #	Price/E
3"	<b>300-DP-ALPH</b>	<b>\$42.15</b>
4"	<b>400-DP-ALPH</b>	<b>42.15</b>



4"

### Reelcraft® Static Discharge Reel

**Applications:**

- Used to ground equipment in hazardous atmospheres, such as fuel trucks or carts transferring flammable materials. When properly clamped to ground, the static discharge reel dissipates static electrical buildup, reduced the chances of sparking and the potential for explosion.

**Features:**

- supplied with a 3/32" OD steel aircraft cable
- DC resistance is approximately one ohm per 50' of steel cable



Description	Stranded Steel	
	Part #	Price/E
single 7" x 7" stranded steel	<b>G3050</b>	<b>\$675.00</b>



## TFA Series Fill Pipe Adapter

**Feature:**

- for use with 3" drop elbows (**300-TFG**)

Adapter Size	Female NPT	Aluminum Hardcoat		Optional Qty
		Part #	Price/E	
3"	3"	<b>300-TFA</b>	<b>\$62.65</b>	10

## Fuel Delivery Tank Adapters



with NPSM thread



with NPT thread

**Features:**

- for use with 4" drop and co-axial elbows (6200, 6400 and 6500 series)
- **BZ4051S** has NPSM thread and is supplied with a gasket

Adapter Size	Female Thread	Height	Bronze		Optional Qty
			Part #	Price/E	
4"	4" NPSM	2 $\frac{3}{8}$ "	<b>BZ4051S</b>	<b>\$110.55</b>	5
	4" NPT	3 $\frac{1}{2}$ "	<b>BZ4051</b>	<b>132.50</b>	5

## Vapor Recovery Tank Adapters

**Features:**

- for use with dual point vapor elbows (VR6200 series)
- can also be used as vapor valve on tanker but does not have air interlock mount
- poppeted vapor collar at station vapor outlet
- low profile design
- replacement parts are available, contact Dixon® for more information

Adapter Size	Female Thread	Height	Material	Part #	Price/E	Optional Qty
4"	4" NPT	3 $\frac{5}{8}$ "	bronze	<b>VR4086</b>	<b>\$313.25</b>	5
			ZN-AL alloy	<b>VR4086-BY</b>	<b>246.60</b>	5

## Vapor Caps

### Aluminum

**Features:**

- special locking cap for underground tank vapor outlet **VR4086** and tanker vapor valves
- bronze cam arms
- painted vapor recovery orange



Size	Aluminum	
	Part #	Price/E
4"	<b>VR4050AL</b>	<b>\$108.40</b>

### Nylon

**Features:**

- centered 'T' handle allows for one-handed use and provides a solid locking mechanism
- strong and lightweight
- built-in locking feature
- corrosion resistant materials
- vapor recovery orange
- replacement parts are available, contact Dixon® for more information



Size	Nylon	
	Part #	Price/E
4"	<b>VR4050PL</b>	<b>\$66.75</b>

## Automatic Pressure / Vacuum Relief Caps

**Features:**

- normally closed, stops fuel evaporation and airborne contaminants
- lockable
- relieves pressure and vacuum buildup in fuel tanks

Note: Pressure/vacuum relief caps should be routinely inspected to ensure correct operation and particularly to ensure that the relieving components are free to move and that the air flow path is unblocked.



### for stationary fuel tanks

**Feature:**

- relieves vacuum at .7 Hg (.33 PSI) and pressure at 2 PSI, 20 SCFM flow

Male NPT	Zinc	
	Part #	Price/E
2"	<b>2000L</b>	<b>\$45.85</b>
2½"	<b>2500L</b>	<b>48.30</b>



### for mobile fuel tanks

**Feature:**

- relieves vacuum at .33 Hg and pressure between 7.5 - 9 PSI

Male NPT	Zinc	
	Part #	Price/E
2"	<b>200-PV-9</b>	<b>\$99.90</b>



## Standard Vent Caps for Stationary Tanks

**Features:**

- allows venting of tank to atmosphere at all times
- also referred to as a breather cap
- does not have pressure or vacuum valves

Male NPT	Part #	Aluminum	Price/E
2½"	<b>2500SFV</b>		<b>\$43.20</b>

## Fuel Delivery Adapter Cap

**Features:**

- single action locking cap
- bronze cam arms
- replacement parts are available, contact Dixon® for more information

Size	Part #	Aluminum	Price/E	Optional Qty
4"	<b>SA4050AL</b>		<b>\$106.10</b>	10

## Swivel Joints

**Applications:**

- used wherever a leak-proof swivel connection is needed in pipelines or in combination with hoses to eliminate hose twisting
- Industries range from petroleum, petrochemical, refining, mining, distilling, paint, farm irrigation and fertilizing, wastewater treatment plants and food and beverage process equipment. Dixon® swivel joints are found in blending plants, drum filling applications, fluid and dry bulk transfer, vacuum trucks, oil and gas trucks and water trucks. Larger swivels can be found in the steel industry, marine bulk transfer and many more.

**Features:**

- full 360° rotational movement
- wide spacing between dual ball bearing raceways ensures greater load bearing capacity
- precision-machined design ensures alignment and years of trouble-free service
- O-ring dust seal protects the ball races and seals chamber from outside elements
- radius elbow design ensures a smooth flow pattern
- hydrostatic testing is performed on all swivels before shipment

**Options Available:**

- end configurations: female NPT, 150# flanges, TTMA flange, grooved, weld end and many other variations
- seal options: Buna, FKM, PTFE, EPDM, FDA Buna, FFKM
- ball bearing materials: carbon steel, 440 stainless steel, and 316 stainless steel
- grease materials: Lithium, FDA approved/food grade and silicone
- swivels that include oxygen, steam or submerged service can be specifically designed for unique applications (special order)
- 100% full penetration weld
- re-build kits available
- custom swivel options available, contact Dixon® at 888.226.4673

Swivel configurator available on [dixonvalve.com](http://dixonvalve.com)

**O-ring Parts Identification List**

1. O-ring (dust) seal
2. ball retainer screw
3. O-ring (pressure) seal
4. grease fitting
5. ball bearings

**O-ring Features:**

- sizes: 1" - 4"
- O-ring pressure seal ensures a leak-proof seal and smooth rotation with lower torque.
- available working pressure ratings up to 1000 PSI
- available in carbon steel, 316L stainless steel, aluminum, brass and malleable iron

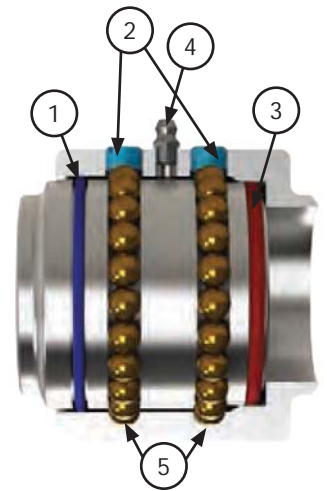
**V-ring Parts Identification List**

1. body
2. sleeve
3. ball bearings
4. seal retainer
5. V-ring (pressure) seal
6. spring retainer
7. ball retainer screw
8. grease fitting
9. O-ring (dust) seal

**V-Ring Features:**

- 2" - 12" size range
- spring loaded triple V-ring sealing system ensures a leak-proof seal at either high or low pressure and extends seal life
- available working pressure ratings up to 1000 PSI
- available in carbon steel, 316L stainless steel and limited aluminum

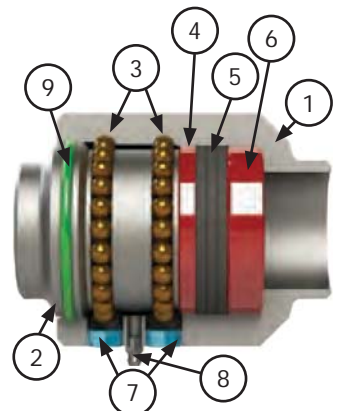

Single Plane Style 20



female NPT x female NPT

Size	Aluminum		Malleable Iron	
	Part #	Price/E	Part #	Price/E
1½"	15020FXFAL00000	\$270.70	15020FXFMI00000	\$342.60
2"	220FXFAL00000	376.15	220FXFMI00000	472.95
3"	320FXFAL00000	435.85	320FXFMI00000	701.10
4"	420FXFAL00000	649.90	---	---

Single Plane Style 30



female NPT x female NPT

Size	Aluminum		Malleable Iron	
	Part #	Price/E	Part #	Price/E
1½"	15030FXFAL00000	\$295.20	15030FXFMI00000	\$374.05
2"	230FXFAL00000	384.15	230FXFMI00000	519.70
3"	330FXFAL00000	519.70	330FXFMI00000	777.55
4"	430FXFAL00000	697.85	---	---

• contact Dixon® at 888.226.4673 for additional sizes, materials and configurations

Swivel Joint Styles Planes of Rotation

Single Plane Style 40



female NPT x female NPT



150# ASA flange x 150# ASA flange

Double Plane Style 50



female NPT x female NPT



150# ASA flange x 150# ASA flange

Double Plane Style 60



female NPT x female NPT



150# ASA flange x 150# ASA flange





## Swivel Joint Styles Planes of Rotation

## Double Plane Style 70



female NPT x female NPT



150# ASA flange x 150# ASA flange

## Triple Plane Style 80



female NPT x female NPT



150# ASA flange x 150# ASA flange

## Triple Plane Style 10



female NPT x female NPT



150# ASA flange x 150# ASA flange

## Working Pressures

Dixon® swivels are recommended for use at the following maximum Non-Shock Cold Working Pressures (NSCWP) provided in PSI, at ambient temperatures **70°F (21°C)**.

Size	V-ring Carbon Steel CS	O-ring Carbon Steel OC	V-ring Stainless Steel SS	O-ring Stainless Steel OS	Aluminum AL	Brass BR	Malleable Iron MI
1"	---	1000	---	1000	150	---	---
1¼"	---	---	---	---	150	---	---
1½"	---	1000	---	1000	150	300	600
2"	1000	1000	1000	1000	150	300	600
3"	1000	1000	1000	1000	150	300	600
4"	1000	---	1000	---	150	---	---
6"	1000	---	---	---	150	---	---
8"	---	---	---	---	150	---	---

- When using flanged ends, the pressure rating will be reduced to coincide with that of the flange being used. Carbon steel and stainless steel 150# flanges are recommended for use at **275 PSI** maximum at ambient temperature **70°F (21°C)**.
- Lubrication should be performed periodically, depending on service and operating conditions. Twice yearly is normally sufficient.
- All dimensions are approximate. Where critical, contact Dixon® at 888.226.4673

## Swivel Ordering Information

Size

Style (shape)

End configuration

Material

Maximum working pressure

Temperature range

Media: specify product being handled (if chemical, advise concentration)

Submerged or oxygen service

If for constant rotation, advise RPM

If for suction service, advise maximum vacuum in inches of mercury (Hg)

Our Sales and Engineering staff will help you evaluate your swivel application, please call 888.226.4673.

Example:  $\frac{2}{[A]}$   $\frac{20}{[B]}$   $\frac{F}{[C]}$  X  $\frac{E}{[C]}$   $\frac{CS}{[D]}$   $\frac{0}{[E]}$   $\frac{0}{[F]}$   $\frac{1}{[G]}$   $\frac{0}{[H]}$   $\frac{0}{[I]}$

<b>A</b> Size					
<b>B</b> Style					
<b>C</b> End Connections	<b>W</b> Weld End	<b>F</b> Female NPT	<b>FG</b> 150# ASA Flange	<b>TF</b> Tank Truck Flange	<b>PF</b> 300# ASA Flange (not available in aluminum)
<b>D</b> Material	<b>CS (V-ring)</b> Carbon Steel OC (O-ring) Carbon Steel	<b>SS (V-ring)</b> Stainless Steel OS (O-ring) Stainless Steel	<b>AL</b> Aluminum	<b>BR</b> Brass	<b>MI</b> Malleable Iron
<b>Code</b>	<b>E</b> Pressure Seal	<b>F</b> Dust Seal	<b>G</b> Retainers	<b>H</b> Ball Bearings	<b>I</b> Grease
0	Buna N (standard)	Buna N (standard)	no retainers (O-ring swivel)	carbon steel (Standard)	Lithium
1	FKM	FKM	aluminum (standard in CS V-ring)	440 grade SS	FDA approved/ food grade
2	PTFE	---	PTFE (standard in SS V-ring)	316 grade SS	Silicone (required with EPR seals)
3	Ethylene Propylene	Ethylene Propylene	---	---	---
4	(requires silicone grease)	(requires silicone grease)	---	---	---



The swivel should be packed such that the surfaces coming in contact with the fluid being handled are compatible with that fluid. In a case where the swivel is being used in a submerged service, this would include the dust seals and ball bearings. We always recommend the use of the stainless steel ball bearings when building a swivel for submerged service. Standard carbon steel ball bearings could rust together, making it impossible to disassemble the swivel and may affect operation.

## Loading Arm Swivels

## Features:

- TTMA loading arm swivel with heavy duty D style shovel handle
- TTMA flanges on both ends
- shovel handle is used to guide the API load coupler onto the adapter on the tank truck
- long radius elbow improves flow into the API load coupler and provides spacing between the load arm and the tank truck
- can be used with flange extensions on page A-31

Size	Description	Aluminum	
		Part #	Price/E
4"	Style 30 short radius, with handle, Buna seals	43HTFXTFAL00000	\$1200.00
	Style 30 short radius, with handle, FKM seals	43HTFXTFAL11000	1230.00
	Style 30 short radius, without handle, Buna seals	430TFXTFAL00000	1150.00
	Style 30 short radius, without handle, FKM seals	430TFXTFAL11000	1280.00
	Style 30 long radius, with handle, Buna seals	43HTFTFLAL00000	1250.00
	Style 30 long radius, with handle, FKM seals	43HTFTFLAL11000	1280.00
	Style 30 long radius, without handle, Buna seals	430FTFTFLAL00000	1200.00
	Style 30 long radius, without handle, FKM seals	430FTFTFLAL11000	1230.00
	Style 40 with handle, Buna seals	44HTFXTFAL00000	1400.00
	Style 40 with handle, FKM seals	44HTFXTFAL11000	1430.00
	Style 40 without handle, Buna seals	440TFXTFAL00000	1350.00
	Style 40 without handle, FKM seals	440TFXTFAL11000	1380.00
	Style 50 with handle, Buna seals	45HTFXTFAL00000	1600.00
	Style 50 with handle, FKM seals	45HTFXTFAL11000	1630.00
	Style 50 without handle, Buna seals	450TFXTFAL00000	1550.00
	Style 50 without handle, FKM seals	450TFXTFAL11000	1580.00



Engineered Fluid  
Transfer Couplings



## Replacement Parts

Description	Part #	Price/E
4" schedule 80 aluminum nipple	ATN100X7	\$25.00
D style heavy duty shovel handle	100DHAN-AL	50.00
buna seal kit	4RKOBU	38.90
FKM seal kit	4RKOVI	60.65



## Split Flange Swivels

## Applications:

- Used in petroleum, blending plants, petrochemical, refining, mining, distilling, paint plants, farm irrigation and fertilizing, wastewater treatment, food and beverage process equipment and marine

## Features:

- bearing pack design allows easy seal change without removing the ball bearings
- simple maintenance: remove one nose piece, replace seal pack, reinstall with little down-time
- instream seal separates wetted area from ball bearings allowing for longer bearing pack life over conventional swivels
- pressure rating: up to **600 PSI**
- temperature: **-40°F to 450°F (-40°C to 232°C)** depending on seal material (with standard seals: **350°F (177°C)**)
- wide set bearing race for higher moment loads
- compact design for low profile applications

## Materials:

- bearing pack: through hardened forged high carbon alloy
- material contact surfaces: stainless steel or carbon steel nose pieces

## Available options:

- stock end configurations: 150 lb. and 300 lb. flanges, FNPT, butt weld, others per request
- stock seals: Baylast™, FKM, PTFE, others per request
- full penetration weld
- contact Dixon® at 888-226-4673 for additional materials and configurations

Size	Carbon Steel Weld x Weld with Baylast™ Pressure Seals		Carbon Steel Weld x Weld with FKM Pressure Seals		Carbon Steel 150# Flange x 150# Flange with Baylast™ Pressure Seals		Carbon Steel 150# Flange x 150# Flange with FKM Pressure Seals	
	Part #	Price/E	Part #	Price/E	Part #	Price/E	Part #	Price/E
2"	SF220WXWCS00	\$1662.00	SF220WXWCS10	\$1659.76	SF220FGXFGCS00	\$1836.00	SF220FGXFGCS10	\$1833.76
3"	SF320WXWCS00	1971.00	SF320WXWCS10	1967.70	SF320FGXFGCS00	2164.00	SF320FGXFGCS10	2160.71
4"	SF420WXWCS00	2269.00	SF420WXWCS10	2256.05	SF420FGXFGCS00	2497.00	SF420FGXFGCS10	2484.05



**NEW**

### Railroad Tank Car Connections

**Features:**

- all swivel nuts have standard 5" Railroad Tank Car thread
- supplied with a Buna-N gasket in the threaded end, other gaskets available on page A-51
- also available in other materials and in 2" and 2½" sizes, consult Dixon® for pricing and availability

**Style A**



Stainless steel railroad tank car connections are not compatible with aluminum and brass.



Male Adapter	Swivel Nut	Elbow	316 Stainless Steel		Aluminum	
			Part #	Price/E	Part #	Price/E
3"	5"	120°	<b>RTCA30</b>	<b>\$815.00</b>	---	---
4"	5"	110°	<b>RTCA40<sup>1</sup></b>	<b>1027.95</b>	<b>ATCA40</b>	<b>\$712.15</b>

<sup>1</sup> parts are produced as a welded fabrication

**Style F**

**Features:**

- 4" TTMA flange can be bolted to sight glass; API adapter or other dry disconnect
- supplied with PTFE Buna-N envelope gasket



110° elbow

TTMA Flange	Swivel Nut	Elbow	Aluminum	
			Part #	Price/E
4"	5"	110°	<b>ATCF40<sup>1</sup></b>	<b>\$708.00</b>
	5"	90°	<b>ATCF40-90</b>	<b>975.00</b>

<sup>1</sup> part is produced as a welded fabrication

• For flange dimensions, diagrams and additional information please reference [dixonvalve.com](http://dixonvalve.com).

**Style GF**

**Feature:**

- 4" TTMA flange can be bolted to sight glass; API adapter or other dry disconnect



110° elbow

TTMA Flange	Boss-lock™ Coupler	Elbow	Aluminum	
			Part #	Price/E
4"	4"	110°	<b>ATCGF40</b>	<b>\$450.00</b>
	4"	90°	<b>ATCGF40-90</b>	<b>450.00</b>

• For flange dimensions, diagrams and additional information please reference [dixonvalve.com](http://dixonvalve.com).

**Screen**

**Feature:**

- stainless steel screen encapsulated in a buna gasket
- for use in Style GF elbows



Size	Hole Size	316L Stainless Steel	
		Part #	Price/E
4"	1"	<b>400-G-BUSS</b>	<b>\$150.00</b>

**Style S**



Shank Size	Swivel Nut	Elbow	Aluminum	
			Part #	Price/E
4"	5"	110°	<b>ATCS40</b>	<b>\$370.45</b>

Railroad Tank Car Connections

Style T

Male NPT	Swivel Nut	Elbow	Iron		Aluminum	
			Part #	Price/E	Part #	Price/E
3"	5"	120°	<b>TCT30</b>	<b>\$265.00</b>	<b>ATCT30</b>	<b>\$292.00</b>
4"	5"	110°	<b>TCT40</b>	<b>320.00</b>	<b>ATCT40</b>	<b>360.00</b>



Style T



Stainless steel railroad tank car connections are not compatible with aluminum and brass.

Male NPT	Swivel Nut	Elbow	316 Stainless Steel	
			Part #	Price/E
3"	5"	120°	<b>RTCT30</b>	<b>\$665.00</b>
4"	5"	110°	<b>RTCT40</b>	<b>780.00</b>



Dixon® Coupler x Tank Car Thread

Features:

- part is produced as a welded fabrication
- pressure rating is based on the seal of the mating part, see ratings on page D-5
- use Dixon® replacement handles only

Coupler	Male Tank Car Thread	Aluminum	
		Part #	Price/E
4"	5"	<b>400DWX5TC</b>	<b>\$500.00</b>



EZ Boss-Lock™ x Coupler Tank Car Thread

Features:

- part is produced as a welded fabrication
- pressure rating is based on the seal of the mating part, see ratings on page D-5
- use EZ Boss-Lock™ replacement handles only

Coupler	Male Tank Car Thread	Aluminum	
		Part #	Price/E
4"	5"	<b>AD400ALEZMTC</b>	<b>\$575.80</b>





### Railroad Unloading Assemblies

**Features:**

- robust aluminum body construction
- removable, easy carry handle
- safe and reliable - valves will not open unless fittings are properly connected
- multiple configurations available, consult Dixon™ for pricing and availability



**Assembly with Mann Tek Dry Disconnect Adapter**

Adapter Size	Swivel Nut Size	Aluminum	
		Part #	Price/E
4"	5"	<b>ATC40ASSDDA</b>	<b>\$2347.65</b>

**Assembly with API Adapter**



**Feature:**

- stainless steel springs on the adapter and coupler for corrosion resistance

Adapter Size	Swivel Nut Size	Aluminum	
		Part #	Price/E
4"	5"	<b>ATC40ASSAPI</b>	<b>\$1860.90</b>

### Dixon® Tank Car Adapters



Stainless steel adapters are not compatible with the aluminum and brass adapters.

**Features:**

- standard 5" Railroad Tank Car thread
- supplied with a Buna-N gasket in the threaded end, see next page for more gaskets



Size	356T6 Aluminum		Brass		Iron		316 Stainless Steel	
	Part #	Price/E	Part #	Price/E	Part #	Price/E	Part #	Price/E
2"	<b>200-TCA-AL</b>	<b>\$121.60</b>	---	---	---	---	<b>200-TCA-SS</b>	<b>\$693.00</b>
3"	<b>300-TCA-AL</b>	<b>105.00</b>	<b>300-TCA-BR</b>	<b>\$350.00</b>	<b>300-TCA-MI</b>	<b>\$257.00</b>	<b>300-TCA-SS</b>	<b>737.40</b>
4"	<b>400-TCA-AL</b>	<b>119.10</b>	<b>400-TCA-BR</b>	<b>420.00</b>	---	---	<b>400-TCA-SS</b>	<b>815.00</b>



**Features:**

- standard 5" Railroad Tank Car thread
- 45° tank car swivel adapter
- unit has a long handle brass swivel nut and a swivel retaining ring
- supplied with a Buna-N gasket in the threaded end, see next page for more gaskets

Size	356T6 Aluminum	
	Part #	Price/E
4"	<b>40A-45TCAL</b>	<b>\$485.85</b>

Note: 4" hose fittings for railroad tank car unloading can be found on pages C-47 and C-48.

Cam & Groove Railroad Tank Car Gaskets



Old Style

Feature:

- for use with Dixon® fittings

Size	OD	ID	Thick	Part #	Leather	Price/E
5"	5¼"	3½"	3/16"	<b>G9</b>		<b>\$15.00</b>



Standard

Feature:

- for use with Dixon® fittings

Size	OD	ID	Thick	Material	Part #	Price/E
5"	5¼"	3⅞"	1/8"	<i>Buna-N</i>	<b>500GTCABU</b>	<b>\$6.55</b>
	5¼"	3⅞"	1/8"	<i>FKM</i>	<b>500GTCAVI</b>	<b>53.50</b>
	5¼"	3⅞"	1/8"	<i>fuel grade Buna</i>	<b>500GTCABF</b>	<b>6.25</b>
	5-5/16"	3⅞"	3/16"	<i>FKM</i>	<b>500GTCAVITHK</b>	<b>32.00</b>



PTFE Envelope

Features:

- for use with Dixon® fittings
- may be too thick for insertion in some older Dixon® fittings

Size	OD	ID	Thick	Material	Part #	Price/E
5"	5¼"	3-13/16"	3/16"	<i>PTFE with Buna-N filler</i>	<b>500GTCATF</b>	<b>\$65.00</b>
	5¼"	3-13/16"	3/16"	<i>PTFE with FKM filler</i>	<b>500GTCATV</b>	<b>112.00</b>



Pin Lug Wrench

Feature:

- used on aluminum and iron tank car nuts

Part #	Iron	Price/E
<b>G10</b>		<b>\$115.00</b>



## Bronze Sight Flow Indicators

## Female NPT x Female NPT

## Features:

- verifies flow and monitors color and clarity in fluid lines
- double window snap ring design
- bronze body
- ABS indicator
- tempered soda lime sight glass
- Buna-N seals
- maximum operating pressure: **125 PSI**
- maximum temperature: **200°F (93°C)**
- made in the USA



Size	Overall Length	Width	Height	Bronze		Optional Qty
				Part #	Price/E	
½"	3-13/16"	2-7/16"	2-7/16"	<b>SF1631-050</b>	<b>\$379.15</b>	1
¾"	3-13/16"	2-7/16"	2-7/16"	<b>SF1631-075</b>	<b>405.10</b>	1
1"	4-3/8"	3"	3-1/8"	<b>SF1631-100</b>	<b>514.20</b>	1
1½"	4-5/8"	3-13/16"	4"	<b>SF1631-150</b>	<b>784.25</b>	1
2"	4-5/8"	3-13/16"	4"	<b>SF1631-200</b>	<b>810.25</b>	1

## Stainless Steel Sight Flow Indicators

## Female NPT x Female NPT

## Features:

- verifies flow and monitor color and clarity in fluid lines
- radial sealing method and bolt-on body design provide reliable service with no torquing maintenance required
- white acetal resin, 40% glass filled propeller style indicator is standard and best for observations at a distance or with opaque liquids <sup>1</sup>
- tempered soda lime sight glass <sup>2</sup>
- FKM seals are standard <sup>3</sup>
- maximum operating pressure: **200 PSI at 150°F (66°C)**
- maximum temperature: **225°F (107°C) at 150 PSI**
- made in the USA
- 150# flanged units and other metals are available, consult Dixon® for price and availability.



½"

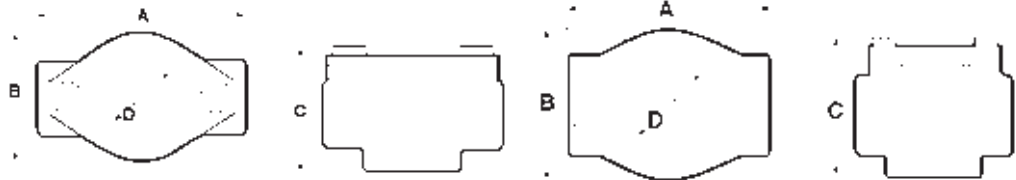

2"

Size	Overall Length A	Width B	Height C	Diameter of Sight Opening D	Stainless Steel		Optional Qty
					Part #	Price/E	
½"	3¼"	2"	2-3/8"	1⅞"	<b>SF1471-050</b>	<b>\$794.65</b>	1
¾"	4¼"	2-9/16"	3-1/4"	1½"	<b>SF1471-075</b>	<b>857.00</b>	1
1"	4¼"	2-9/16"	3-1/4"	1½"	<b>SF1471-100</b>	<b>1080.30</b>	1
1½"	5⅝"	3-5/16"	4-5/16"	2"	<b>SF1471-150</b>	<b>1433.50</b>	1
2"	5⅝"	3-5/16"	4-5/16"	2"	<b>SF1471-200</b>	<b>1687.95</b>	1

<sup>1</sup> Plain, flapper or drip tube style indicators are available as are PTFE indicators, consult Dixon® for price and availability.

<sup>2</sup> Special units with tempered borosilicate glass are available, consult Dixon® for price and availability.

<sup>3</sup> PTFE, EPR and Buna-N seals are available, consult Dixon® for price and availability.