

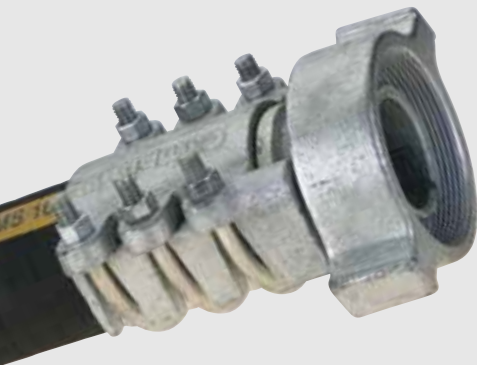

Couplings for High-Pressure Air and Steam Hose

Campbell Crimpnology™ offers hose assembly systems for your high-pressure steam and air applications.

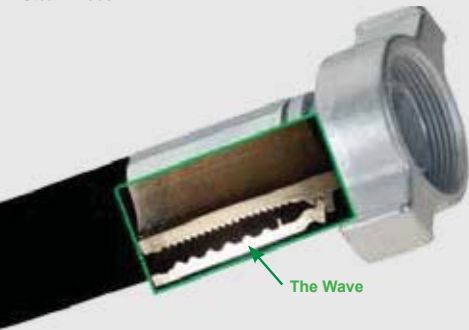
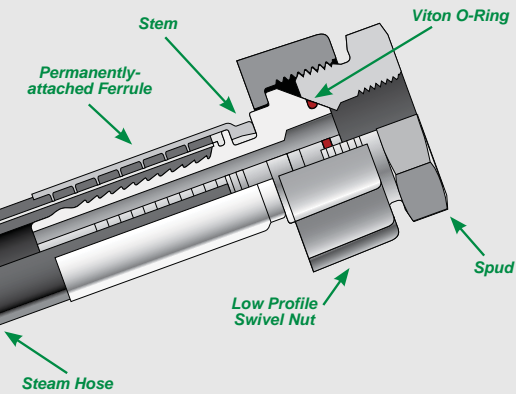
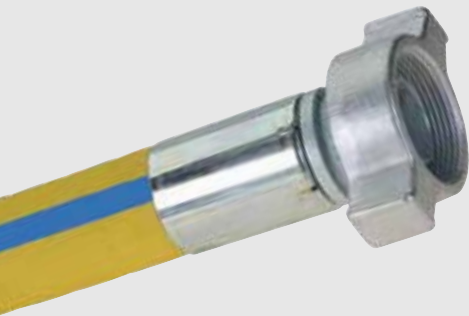

VITON® SEAL GROUND JOINT COUPLINGS, AIR HAMMER COUPLINGS, AND MALE STEMS

Features & Benefits

- Viton® Seal Couplings pass 1000 hour MIL-H-29210 steam test.
- Eliminates leaks with hand-tightened nut.
- DuPont Viton® seal on hose stem is formulated for high pressure steam and air applications.
- Interchangeable with old-style ground joint couplings.
- Machined from carbon steel, cast ductile iron (meets ASTM A395 specification), and 316 stainless steel. *See picture on right.

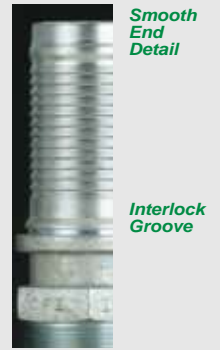

STAKED-ON FERRULE FOR STEAM HOSE

Features & Benefits

- Designed specifically for certain hose brands. Check with factory for information.
- Viton® Seal Couplings pass 1000 hour MIL-H-29210 steam test.
- Crimped steam assemblies eliminate the need for retightening bolts.
- Eliminates leaks and cuts costs caused by leaky clamps.
- Ferrule serrations bite to the wire achieving electrical continuity.
- Meets 250 PSI pressure rating for steam applications.

SWIVEL INTERLOCKING MALE STEM

Features & Benefits

- Designed for use with steam.
- Available with staked-on ferrule for crimped steam applications.



NEW! HEATWAVE GROUND JOINT COUPLING SYSTEM

Features & Benefits

- Engineered to solve hose retention safety issues created by excessively high temperatures.
- One piece coupling/ferrule design.
- Machined ferrule utilizes a wave pattern, which gently displaces the hose evenly while pressing the tube into the coupling serrations.

Recommended Use

- Install one length of HeatWave Hose System at the compressor outlet to dissipate heat. Then attach standard crimped air hoses from the HeatWave System to the tools.

*See drawing below.

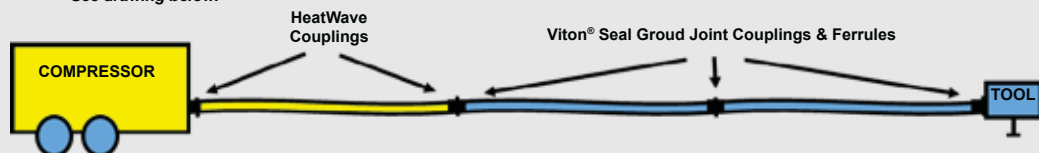

INTERLOCKING U-BOLT CLAMPS

Features & Benefits

- 360° design wraps completely around hose for superior retention.
- Clamps fit hoses tightly without cracking, eliminating costly rework.
- Bolts on “up side” allow easier tightening/retightening and improve “dragability”.
- Field repairable.

Hose System Components			MAX. SYSTEM WORKING PRESSURE (PSI @ 70°F) SEE NOTE 1								
			Hose Size								
Fitting/Coupling	Attachment	Hose Type	1/2	3/4	1	1-1/4	1-1/2	2	2-1/2	3	4
Viton® Ground Joint/Air Hammer/Male Stem	U-Bolt Clamp	Rubber/Steam	1500	1250	1250	1250	1250	1250	800	500	500
Viton® Ground Joint/Male Stem	Staked-on Ferrule	Steam	1250	1250	1250	-	-	call	-	call	-
Viton® Ground Joint/Air Hammer/Male Stem	Long Ferrule	Rubber	1000	1000	1000	1000	1000	1000	650	500	500
HeatWave Coupling/HW Male	Staked-on Ferrule	Rubber	-	-	-	-	-	call	-	call	-



**VITON® SEAL
GROUND
JOINT
COUPLINGS**

DISTRIBUTOR AUTHORIZATION

Safety is of paramount concern to everyone. Due to the volatile nature of compressed air and steam, and in accordance with our ISO 9001 quality system, we reserve the right to restrict sales of our Ground Joint Viton® Seal Couplings and U-Bolt Clamps to only those distributors authorized by Campbell Fittings.

Please contact our Customer Service department for more information.

**FEMALE SET
(with low-profile nut)**

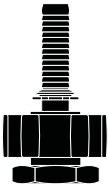

Steel/Ductile Iron			
hose size	part number	list each	
1/2	RGJF-2	33.70	
3/4	RGJF-3	42.38	
1	RGJF-4	42.38	
1-1/4	RGJF-5	75.06	
1-1/2	RGJF-6	72.03	
2	RGJF-8	86.76	
2-1/2	RGJF-10	227.17	
3	RGJF-12	231.02	
4	RGJF-16	523.98	

316 Stainless			
hose size	part number	list each	
1/2	RGJFSS-2	268.43	
3/4	RGJFSS-3	278.48	
1	RGJFSS-4	308.32	

**FEMALE SET
(with wing nut)**

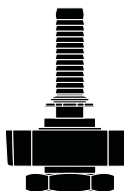

Steel/Ductile Iron			
hose size	part number	list each	
1/2	GJF-2	33.54	
3/4	GJF-3	41.97	
1	GJF-4	42.38	
1-1/4	GJF-5	75.06	
1-1/2	GJF-6	72.03	
2	GJF-8	88.44	
2-1/2	GJF-10	224.96	
3	GJF-12	225.88	
4	GJF-16	494.72	

**VITON® SEAL HOSE STEM
(staked-on ferrule & low profile nut)**



Steel			
hose size	part number	list each	
1/2	RGJS-2**	**	
3/4	RGJS-3**	**	
1	RGJS-4**	**	
1-1/2	RGJS-6**	**	
2	RGJS-8**	**	

316 Stainless			
hose size	part number	list each	
1/2	RGJSS-2**	**	
3/4	RGJSS-3**	**	
1	RGJSS-4**	**	

**VITON® SEAL HOSE STEM
(staked-on ferrule & wing nut)**



Steel			
hose size	part number	list each	
1/2	GJS-2**	**	
3/4	GJS-3**	**	
1	GJS-4**	**	
1-1/2	GJS-6**	**	
2	GJS-8**	**	

**INTERLOCKING MALE STEM
(with staked-on ferrule)**



Steel			
hose size	part number	list each	
1/2	IMS-2**	**	
3/4	IMS-3**	**	
1	IMS-4**	**	
1-1/2	IMS-6**	**	
2	IMS-8**	**	

316 Stainless			
hose size	part number	list each	
3/4	IMSS-3**	**	
1	IMSS-4**	**	

**SWIVEL MALE STEM
(with staked-on ferrule
for use with steam)**



Steel			
hose size	part number	list each	
3/4	IMS-3**SW	**	
1	IMS-4**SW	**	

316 Stainless			
hose size	part number	list each	
3/4	IMSS-3**SW	**	

****Contact Customer Service for part numbers, prices, and availability**

**HEATWAVE FEMALE SET
(staked-on ferrule & wing nut) NEW!**



Steel/Ductile Iron			
hose size	part number	list each	
2	GJF-8 HW	224.18	
3	GJF-12 HW	518.17	

**HEATWAVE MALE STEM
(with staked-on ferrule) NEW!**



Steel/Ductile Iron			
hose size	part number	list each	
2	IMS-8 HW	142.83	
3	IMS-12 HW	383.63	

INTERLOCKING MALE STEM



Steel			
npt x hose	part number	list each	
1/2	IMS-2	6.77	
1/2 X 3/4	IMS-2X3	15.33	
3/4 X 1/2	IMS-3X2	19.53	
3/4	IMS-3	10.38	
3/4 X 1	IMS-3X4	23.91	
1 X 3/4	IMS-4X3	23.49	
1	IMS-4	15.19	

Machined Ductile Iron

1-1/4	IMS-5	24.03	
1-1/2	IMS-6	26.27	
2	IMS-8	36.56	
2-1/2	IMS-10	66.96	
3	IMS-12	91.33	
4	IMS-16	160.73	

316 Stainless

1/2	IMSS-2	66.15	
3/4	IMSS-3	67.20	
1	IMSS-4	68.25	

**SWIVEL MALE STEM
(for use with steam)**



Plated Steel			
hose size	part number	list each	
3/4	IMS-3SW	39.40	

Viton® should never be used with ammonia. Please contact our Engineering department for information on all our different gasket materials.

VITON® SEAL HOSE STEM



Steel			
hose size	part number		list each
1/2	GJS-2		10.38
3/4	GJS-3		18.73
1	GJS-4		18.73

Machined Ductile Iron			
size	part number		list each
1-1/4	GJS-5		28.88
1-1/2	GJS-6		29.56
2	GJS-8		37.07
2-1/2	GJS-10		61.72
3	GJS-12		94.53
4	GJS-16		175.43

316 Stainless			
size	part number		list each
1/2	GJSS-2		96.20
3/4	GJSS-3		103.20
1	GJSS-4		131.19

**VITON® SEAL MALE END
 (Viton® Seal x male npt)**



Plated Steel			
npt size	part number		list each
3/4	GJMS-3		52.59
1	GJMS-4		52.59
1-1/2	GJMS-6		85.94
2	GJMS-8		92.43

316 Stainless			
size	part number		list each
3/4	GJMSS-3		143.82
1	GJMSS-4		268.10

**VITON® SEAL FEMALE END
 (Viton® Seal x female npt)**



Plated Steel			
npt size	part number		list each
3/4	GJFS-3		107.85

FEMALE SPUD



Steel			
npt size	part number		list each
1/2	GFS-2		17.87
3/4	GFS-3		14.16
1	GFS-4		14.16

Machined Ductile Iron			
size	part number		list each
1-1/4	GFS-5		31.11
1-1/2	GFS-6		29.43
2	GFS-8		32.91
2 X 3/4	GFS-8X3		54.63
2-1/2	GFS-10		88.84
3	GFS-12		77.83
4	GFS-16		168.78

316 Stainless			
size	part number		list each
1/2	GFSS-2		81.50
3/4	GFSS-3		88.32
1	GFSS-4		90.00

MALE SPUD



Steel			
npt size	part number		list each
1/2	GMS-2		23.59
3/4	GMS-3		22.28
1	GMS-4		23.43

Machined Ductile Iron			
size	part number		list each
1-1/4	GMS-5		53.32
1-1/2	GMS-6		51.37
2	GMS-8		54.11
2-1/2	GMS-10		133.12
3	GMS-12		140.55

DOUBLE SPUD



Steel			
size	part number		list each
1/2	GDS-2		38.77
3/4	GDS-3		36.14
1	GDS-3		36.14

Machined Ductile Iron			
size	part number		list each
1-1/4	GDS-5		64.62
1-1/2	GDS-5		64.62
2	GDS-8		64.54
2-1/2	GDS-10		137.32
3	GDS-12		145.39

SOCKET WELD SPUD



316 Stainless			
size	part number		list each
3/4	GWSS-3		88.32
1	GWSS-4		90.00

LOW PROFILE NUT



Machined Ductile Iron			
size	part number		list each
1/2	RGN-2		5.79
3/4	RGN-3		9.44
1	RGN-3		9.44
1-1/4	RGN-5		14.69
1-1/2	RGN-5		14.69
2	RGN-8		16.41
2-1/2	RGN-10		68.64
3	RGN-12		59.79
4	RGN-16		169.62

316 Stainless			
size	part number		list each
1/2	RGNSS-2		85.18
3/4	RGNSS-3		95.71
1	RGNSS-3		95.71

WING NUT



Machined Ductile Iron			
size	part number		list each
1/2	GN-2		5.79
3/4	GN-3		9.44
1	GN-3		9.44
1-1/4	GN-5		14.69
1-1/2	GN-5		14.69
2	GN-8		16.41
2-1/2	GN-10		68.64
3	GN-12		59.79
4	GN-16		169.62

DEAD-END



size	part number		list each
3/4	GDC-3		55.86
1	GDC-3		55.86

VITON® O-RING



size	part number		list each
1/2	VO-2		1.02
3/4	VO-3		1.19
1	VO-3		1.19
1-1/4	VO-5		2.19
1-1/2	VO-5		2.19
2	VO-8		3.03
2-1/2	VO-10		4.63
3	VO-12		6.37
4	VO-16		7.04

All steel and machined ductile iron parts are zinc plated. DuPont Viton® is the best O-Ring material for couplings used in both Air and Steam applications. For special applications, O-Rings of other materials are available upon request.



FEMALE SET (with low profile nut)



Steel/Ductile Iron			
hose size	part number	list each	
3/4	RHJF-3	59.36	
1	RHJF-4	54.44	

FEMALE SET (with wing nut)



Steel/Ductile Iron			
hose size	part number	list each	
3/4	HJF-3	62.33	
1	HJF-4	54.44	

HOSE STEM



Steel			
hose size	part number	list each	
3/4	HJS-3	20.97	
1	HJS-4	17.40	

FEMALE SPUD



Steel			
npt size	part number	list each	
3/4	HFS-3	26.24	
1	HFS-4	23.12	

MALE SPUD



Steel			
npt size	part number	list each	
3/4	HMS-3	37.11	
1	HMS-4	34.84	

LOW PROFILE SWIVEL NUT



Ductile Iron			
size	part number	list each	
3/4	RHN-3	14.89	
1	RHN-3	14.89	

WING NUT



Ductile Iron			
size	part number	list each	
3/4	HN-3	13.92	
1	HN-3	13.92	

DOUBLE SPUD



Steel			
size	part number	list each	
3/4	HDS-3	34.39	
1	HDS-3	34.39	

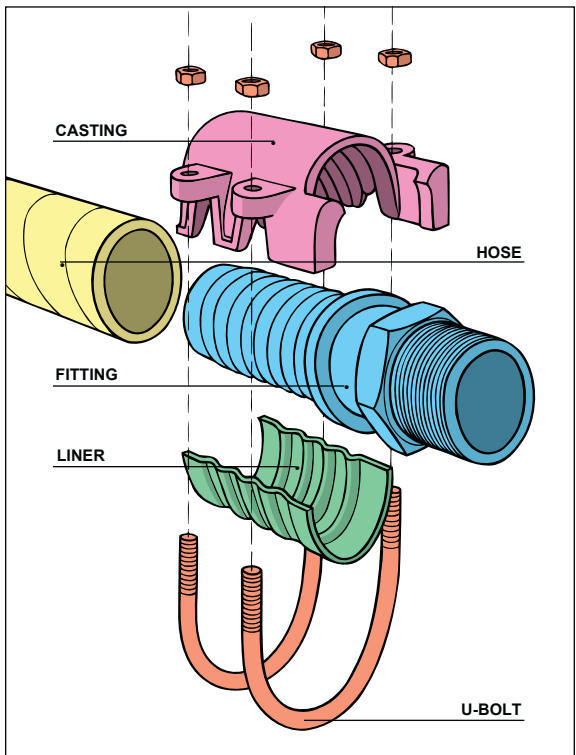
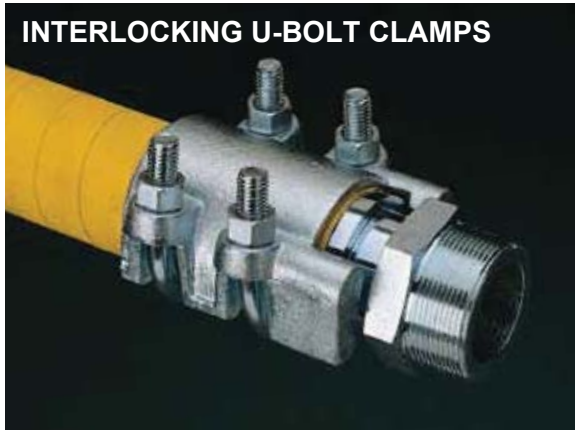

This 2" 1000 psi rated hose exploded in a test at 5200 psi. The hose exceeded its minimum 4X safety factor. The fitting and clamp exceeded the capacity of the hose.

SINGLE U-BOLT



hose o.d. min	hose o.d. max	hose size	part number	list each
13/16	1-1/32	1/2	IC-2	8.49
1-1/16	1-1/4	3/4	IC-3S	10.99
1-3/32	1-3/8	3/4	IC-3	10.99

DOUBLE U-BOLT



hose o.d. min	hose o.d. max	hose size	part number	list each
1-5/16	1-1/2	1	IC-4	18.67
1-1/2	1-11/16	1	IC-4L	18.94
1-9/16	2	1-1/4	IC-5	31.03
1-15/16	2-3/16	1-1/2	IC-6	26.25
2-3/16	2-3/8	1-1/2	IC-6L	28.62
2-11/32	2-11/16	2	IC-8	39.50
2-11/16	2-15/16	2	IC-8L	35.86
3	3-9/32	2-1/2	IC-10	52.68
3-9/32	3-9/16	2-1/2	IC-10L	67.49

TRIPLE U-BOLT

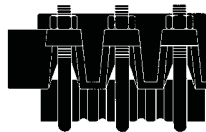

hose o.d. min	hose o.d. max	hose size	part number	list each
3-5/16	3-3/4	3	IC-12S	77.59
3-11/16	4-1/8	3	IC-12	83.63
4-1/16	4-1/2	3	IC-12L	116.67
4-5/16	4-3/4	4	IC-16S	221.87
4-11/16	5-1/8	4	IC-16	232.34
5-1/16	5-1/2	4	IC-16L	381.01
7-11/16	8-1/4	6	IC-24L	420.23

For your convenience, U-Bolts are available in bulk packages, upon request. Bulk package price is the same as listed above. (IC-2 through IC-4L are packed 25 per carton. IC-5 through IC-8L are packed 10 per carton.)

WHIP CHEK™ SAFETY CABLE (hose to hose)

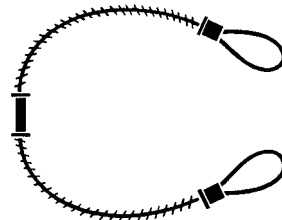

hose size	part number	list each
1/2	WC-1	26.08
3/4	WC-1	26.08
1	WC-1	26.08
1-1/4	WC-2	40.74
1-1/2	WC-2	40.74
2	WC-2	40.74
3	WC-2	40.74
4	WC-4	99.17