





**KIT ITEM #**

---

**IMPORTANT! After maintenance or reassembly, use new fasteners and torque fasteners as follows:**

\_\_\_\_\_ FT LBS      \_\_\_\_\_ IN LBS      \_\_\_\_\_ Nm

**Torque specifications are based on the replacement bladder kit ordered. Check torque specifications to dampener tag. Consult factory if specifications do not match dampener tag or tag is missing.**

-  **Read and observe all safety warnings and instructions in the Installation and Operation Manual before dampener installation, operation or repair.**
-  **WARNING! Remove all pressure from dampener AND pumping system before disassembly, removal or maintenance.**
-  **CAUTION! Replace nut and bolt fasteners at each reassembly with fasteners of equal grade/strength value. DO NOT reuse old nuts and bolts. Fasteners may lose strength when re-torqued. Warranty voided for failure to replace both nuts and bolts when reassembling.**
-  To avoid possible damage to bladder from a system pressure test:
  - Adjustable and Chargeable models** — charge dampener to 80% of the system test pressure prior to test.
  - Automatic model** — prior to test, dampener must be equipped with a constant source of compressed air with pressure equal to or greater than system test pressure.
  - Inlet Stabilizer model** — maximum pressure test 30 psi (2.0 bar), charge to 20 psi (1.3 bar) for system pressure test.

### BLADDER Replacement

1. Disassemble dampener by removing fasteners securing wetted and non-wetted chambers. Make sure all components are clean and free of corrosion. Order replacement parts as needed.
2. Remove and discard the old elastomeric bladder. Install the new elastomeric bladder into the wetted chamber (bottom) of the dampener with the bottom of the bladder in the down position so that it fits within the wetted chamber with the open end facing up.
3. Reassemble dampener by securing the non-wetted chamber (top) to the wetted chamber (bottom). For models with ring band fasteners, reinstall ring bands on wetted and non-wetted chambers with bolt holes aligned. Secure dampener assembly with new bolts, nuts and washers. The gap between the non-wetted and wetted chambers must remain even all around the unit.
4. Tighten bolts in a criss-cross pattern as shown in FIGURE 1, and torque to specifications on dampener tag. **DO NOT reuse old nuts and bolts. New nuts and bolts must be of equal grade/strength value.**
5. To reinstall dampener, refer to the appropriate Installation and Operation Manual for complete instructions.

### HIGH PRESSURE Bladders

High pressure elastomeric bladders are equipped with a reusable stainless steel anti-extrusion button (see FIGURE 2).

1. The anti-extrusion button ② is removable from a failed bladder and can be installed in the replacement bladder by removing the screw ③ holding the two halves of the button in place.
2. The elastomeric bladder ① has a hole in the center to accommodate the screw ③. Place the screw into the disk ④ that is flat on both sides and thread the screw from the inside of the bladder through the hole in the bladder.
3. Take the disk ④ that is tapered on one side and attach it securely to the screw ③. Use blue thread locker to prevent thread backout.
4. Insert the bladder ① into the wetted chamber (bottom) of the dampener and reassemble according to instructions above.
5. **VITON Bladders:** For high pressure VITON bladders with anti-extrusion button, charge dampener after reassembly to an initial pressure of 100 psi (6.9 bar). Dampener must remain at that pressure for a minimum of 3 hours to pre-condition the bladder before reinstallation.

FIGURE 1

Bolt Tightening Pattern

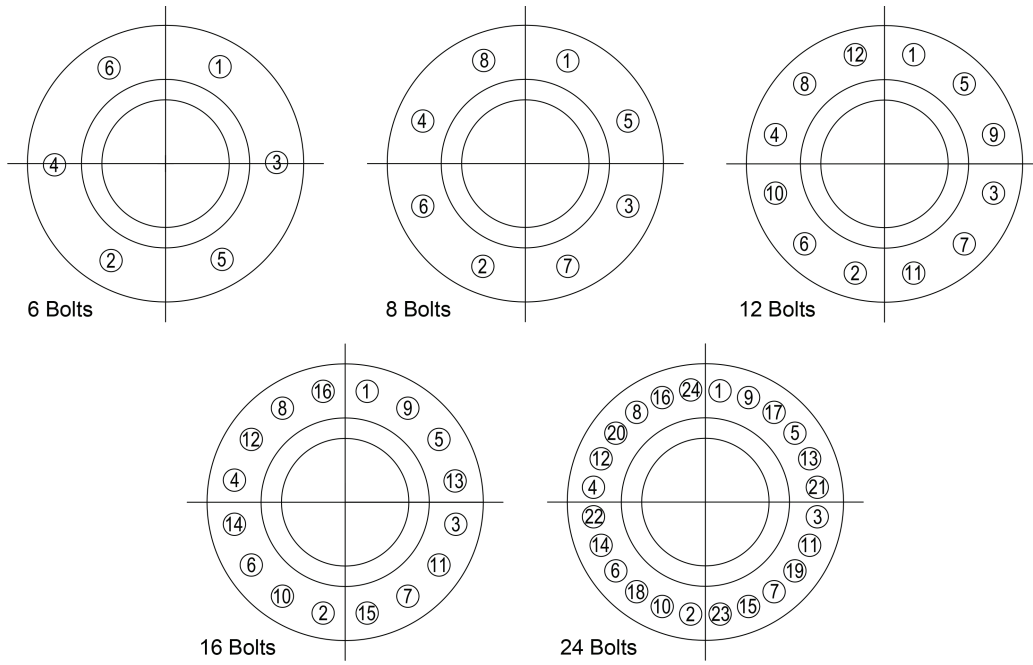
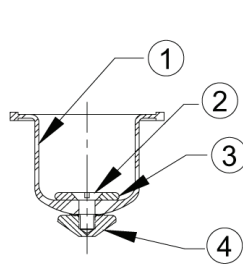

FIGURE 2

High Pressure Bladders

- ① Elastomeric Bladder
- ② Anti-Extrusion Button
- ③ Screw
- ④ Disk



4 / 10 cu in

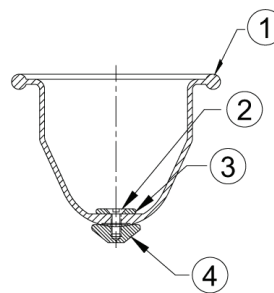

36 / 85 cu in

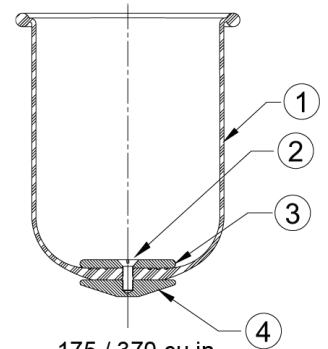

175 / 370 cu in

M71E11\_031